





SPECIFICATION FOR LCD MODULE

MODULE NO: YB-TG320240S22A-N-A0

Doc.Version:00

Customer Approval:

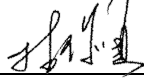
<input type="checkbox"/> Accept	<input type="checkbox"/> Reject
---------------------------------	---------------------------------

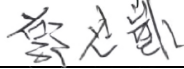
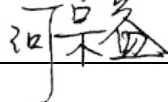
YEEBO	NAME	SIGNATURE	DATE
Prepare	Electronic Engineer		2019.01.18
Check	Mechanical Engineer		2019-01-18
Verify			2019-01-18
Approval			2019/1/18

APPROVAL FOR SPECIFICATIONS ONLY

APPROVAL FOR SPECIFICATIONS AND SAMPLE

WIMRD005-02-D

1. Revision History

Sample Version	DOC. Version	DATE	DESCRIPTION		CHANGED BY
A0	00	2019-01-18	SPEC ONLY	First issue	Shien/CFJ

2. Table of Contents:

NO	CONTENTS	PAGE
1	Revision History	1
2	Table of Contents	2
3	Module Numbering System	3
4	General Specification	4
5	LCM drawing	5
6	Electrical Characteristics	6
7	Optical Characteristics	10
8	Interface Pin Assignment	12
9	Block Diagram	13
10	Backlight	14
11	Standard Specification for Reliability	15
12	Specification of Quality Assurance	17
13	Handling Precaution	25
14	Guarantee	25

3. Module Numbering System:

YB - T G 240320 S 01 D - T - A0

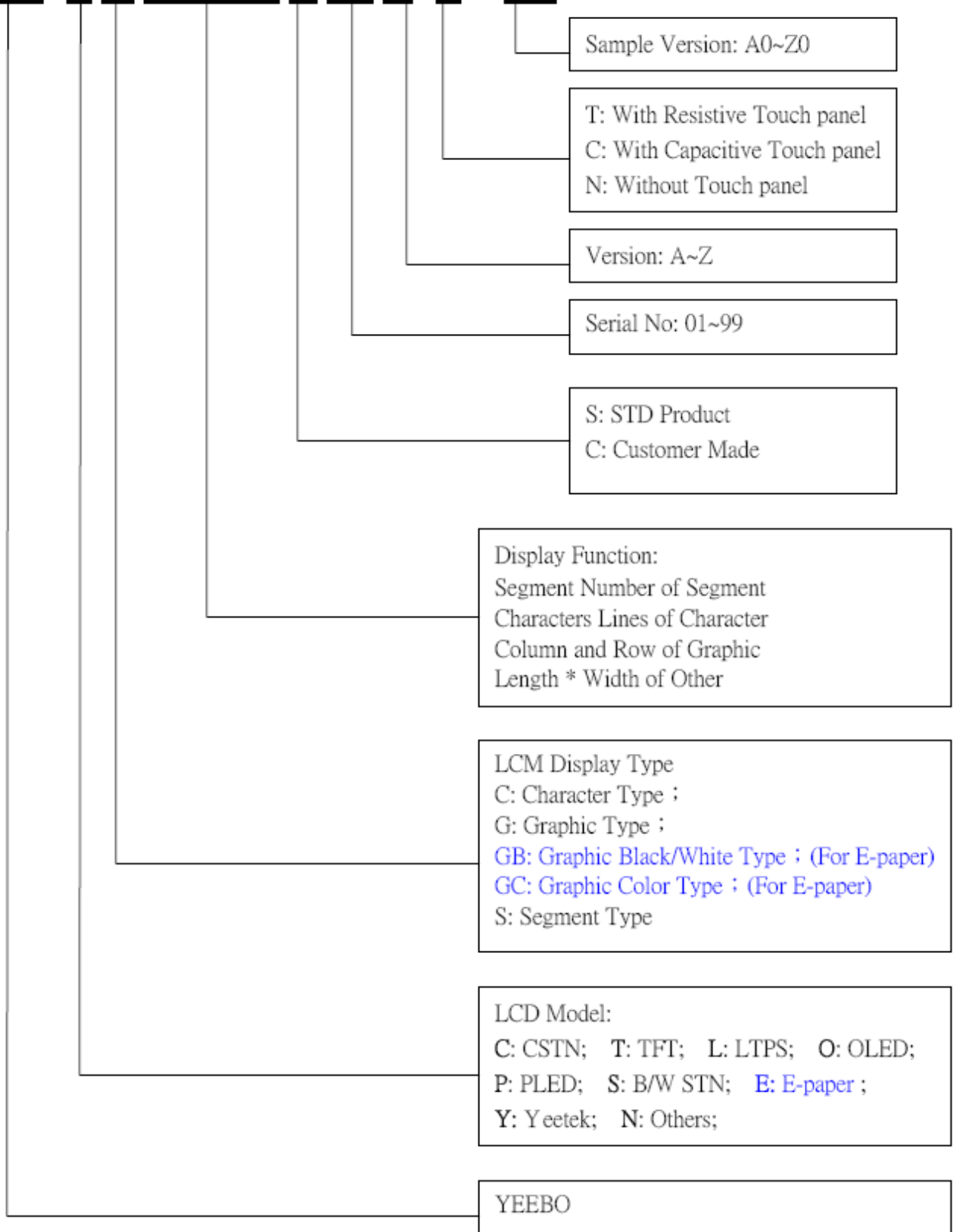

4. General Specification:

ITEM	CONTENTS
Module Size	76.9 (W) * 63.9 (H) * 3.15(T) mm
Module Size(With FPC)	76.9 (W) * 102.9 (H) * 3.15(T) mm
Display Size(Diagonal)	3.5 inch
Display Format	320(BGR) * 240 Pixels
Active Area	70.08(W) * 52.56(H) mm
Pixel Pitch	0.219 * 0.219 mm
LCD Type	TFT(262K) / Transmissive/NB
Viewing Direction (Gray Inversion)	FREE
Controller IC	ST7272A
Weight	TBD.

5. LCM drawing:

Count drawing & Spec.revision record during discussion with customer		Date
Rec:	Revision content description	2019-01-18
#1	FIRST ISSUE	

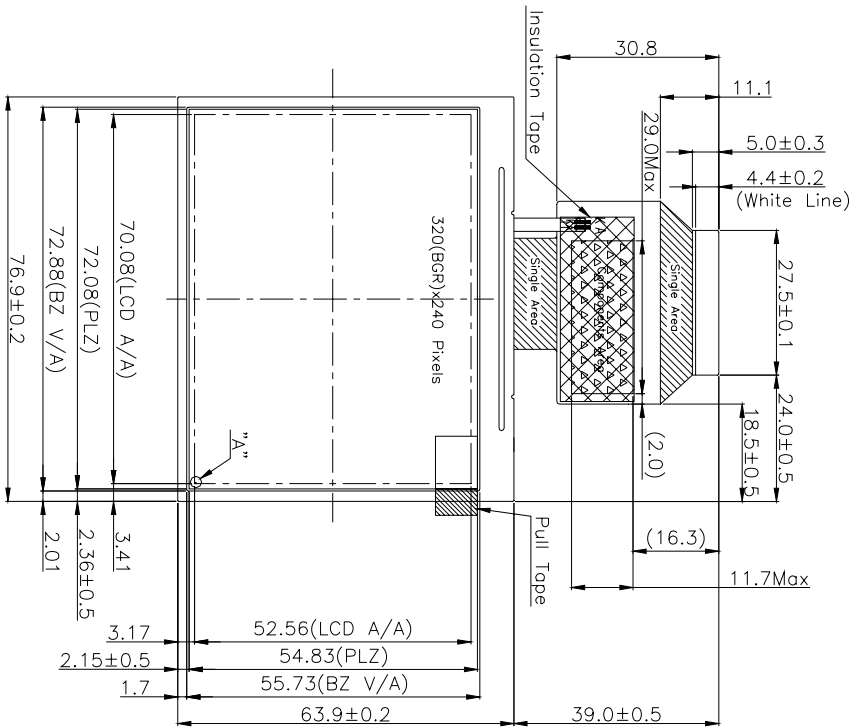

- Specification:**
1. Display mode: 3.5" TFT(16.7M) / Transmissive / Normally Black
 2. Viewing direction: Free
 3. Operating temperature: -20°C to +70°C
Storage temperature: -30°C to +80°C
 4. Drive IC is: ST7272A or Compatible
 5. Back Light: White (LEDx6)
 6. Unspecified tolerance: ±0.30mm.
 7. ROHS compliant

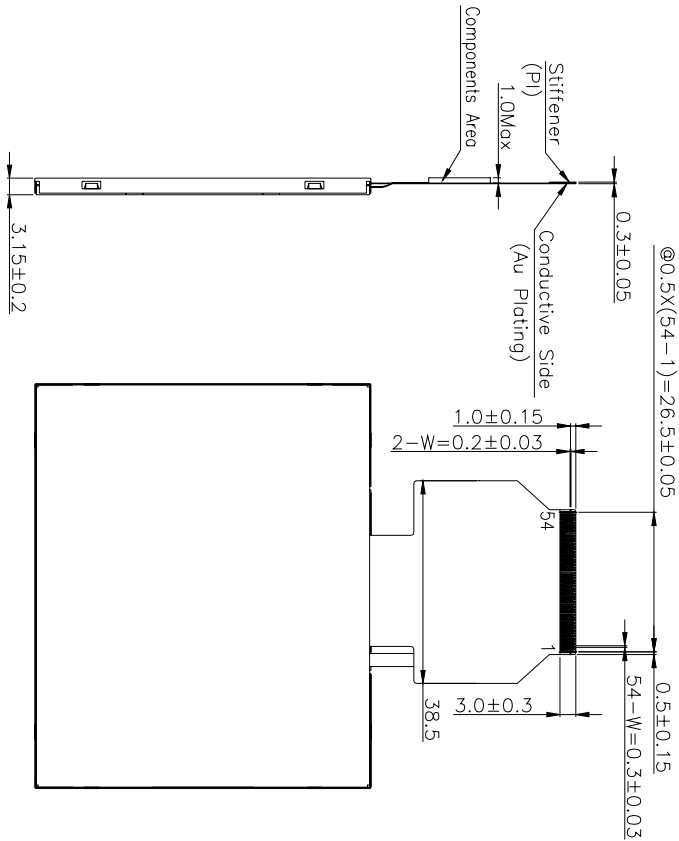
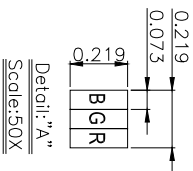

CIRCUIT DIAGRAM
B/L Electrical Circuit



YEEBO		MOD. Name	YB-TG320240S22A-N-A	FILE NAME	Count Dwg.
UNIT	mm	DESIGNED	張豐章	CHECKED	
SIZE	A4	SCALE	N-T-S	VERIFIED	
		2019-01-18	APPROVED		
		Sheet	1	Of	1

6. Electrical Characteristics

6-1 Absolute Maximum Ratings

(Ta=25°C VSS=0V)

Item	Symbol	Min.	Type	Max.	Unit	Remark
Power Supply Voltage	VDD-VSS	-0.3	-	+4.0	Volt	Note1
Operating Temperature	Topr	-20	-	+70	°C	-
Storage Temperature	Tstg	-30	-	+80	°C	-

Note1: Absolute maximum rating is the limit value beyond which the IC maybe broken.
They do not assure operations.

6-2 Operating Conditions

(Ta=25°C)

Item	Symbol	Condition	Min.	Typ.	Max.	Unit
Power Supply	VDD.VSS	-	3.0	3.3	3.6	Volt
Input Voltage	V _{IH}	-	0.7 *VDD	-	VDD	V
	V _{IL}	-	0	-	0.3*VDD	V
Power Supply Current for LCM	IDD	VDD=3.3V	-	TBD.	-	mA

6-3 Timing Characteristics

System Bus Timing for I2C Interface

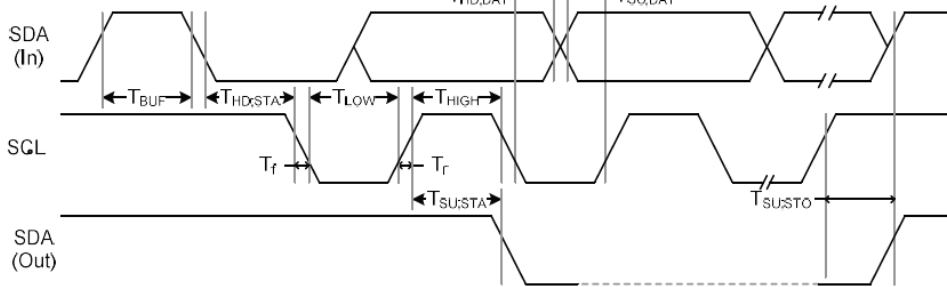

Item	Symbol	Min.	Typ.	Max.	Unit	Conditions
SCL Clock Frequency	FSCL	-	-	400	KHz	
SCL Clock Low Period	TLOW	1300	-	-	ns	
SCL Clock High Period	THIGH	600	-	-	ns	
Signal Rise Time	Tr	20+0.1Cb	-	300	ns	
Signal Fall Time	Tf	20+0.1Cb	-	300	ns	
Start Condition Setup Time	TSU;STA	600	-	-	ns	
Start Condition Hold Time	THD;STA	600	-	-	ns	
Data Setup Time	TSU;DAT	100	-	-	ns	
Data Hold Time	THD;DAT	0	-	900	ns	
Setup Time for STOP Condition	TSU;STO	600	-	-	ns	
Bus Free Time Between a STOP and START	TBUF	100	-	-	ns	
Capacitive load represented by each bus line		Cb		400	pF	

System Bus Timing for 3-Wire SPI Interface

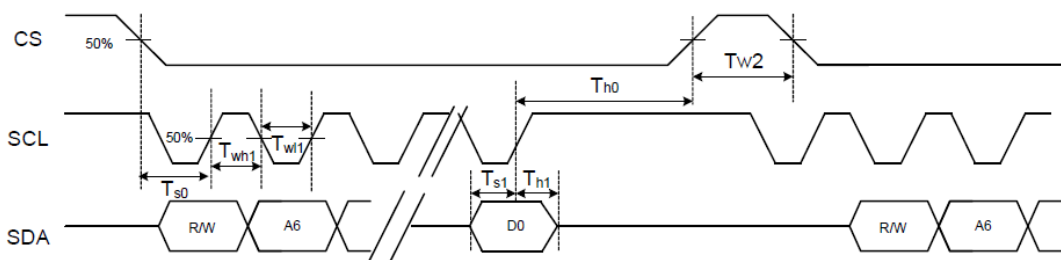

Item	Symbol	Min.	Typ.	Max.	Unit	Conditions
CS Input Setup Time	Ts0	50	-	-	ns	
Serial Data Input Setup Time	Ts1	50	-	-	ns	
CS Input Hold Time	Th0	50	-	-	ns	
Serial Data Input Hold Time	Th1	50	-	-	ns	
SCL Write Pulse High Width	Twh1	50	-	-	ns	
SCL Write Pulse Low Width	Twl1	50	-	-	ns	
SCL Read Pulse High Width	Trh1	300			ns	
SCL Read Pulse Low Width	Trl1	300			ns	
CS Pulse High Width	Tw2	400	-	-	ns	

System Bus Timing for RGB Interface

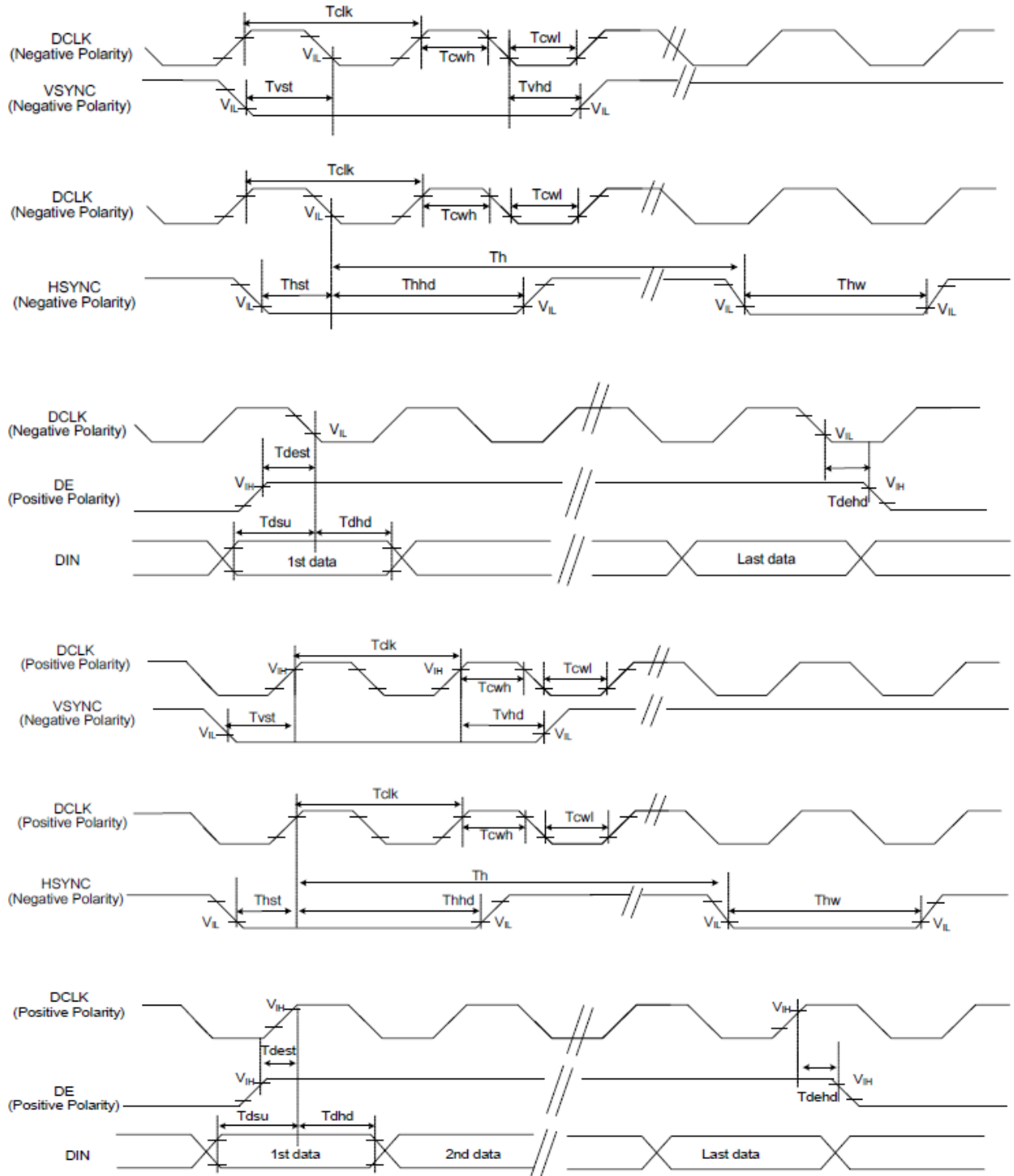

Item	Symbol	Min.	Typ.	Max.	Unit	Conditions
CLK Pulse Duty	Tclk	40	50	60	%	
HSYNC Width	Thw	2	-	-	DCLK	
VSYNC Setup Time	Tvst	12	-	-	ns	
VSYNC Hold Time	Tvhd	12	-	-	ns	
HSYNC Setup Time	Thst	12	-	-	ns	
HSYNC Hold Time	Thhd	12	-	-	ns	
Data Setup Time	Tdsu	12	-	-	ns	
Data Hold Time	Tdhd	12	-	-	ns	
DE Setup Time	Tdest	12	-	-	ns	
DE Hold Time	Tdehd	12	-	-	ns	

7. Optical Characteristics:

Item	Symbol	Conditions	Specifications			Unit	Note	
			Min	Typ	Max			
Transmittance (With PL)	T(%)	-	-	6.2	-	-	-	
Contrast Ratio	CR	$\Theta = 0$ Normal Viewing angle	-	800	-		(1) (2)	
Response time	TR+TF	-	-	30	40	ms	(1) (3)	
Viewing angle	Hor.	Θ_{x+}	CR ≥ 10	-	80	-	deg.	-
		Θ_{x-}		-	80	-		
	Ver.	Θ_{y+}		-	80	-		
		Θ_{y-}		-	80	-		

Measuring Condition

1. Measuring surrounding: dark room
2. Ambient temperature: $25 \pm 2^\circ\text{C}$
3. 30 min. Warm-up time.

Color of CIE Coordinate:

Item		Symbol	Condition	Min.	Typ.	Max.
Chromaticity Coordinates (Transmissive)	Red	x	$\theta = \phi = 0^\circ$ LED Backlight Color Degree	TBD	(0.646)	TBD
		y		TBD	(0.335)	TBD
	Green	x		TBD	(0.323)	TBD
		y		TBD	(0.567)	TBD
	Blue	x		TBD	(0.134)	TBD
		y		TBD	(0.121)	TBD
	White	x		TBD	(0.317)	TBD
		y		TBD	(0.339)	TBD

Note (1) Definition of Viewing Angle :

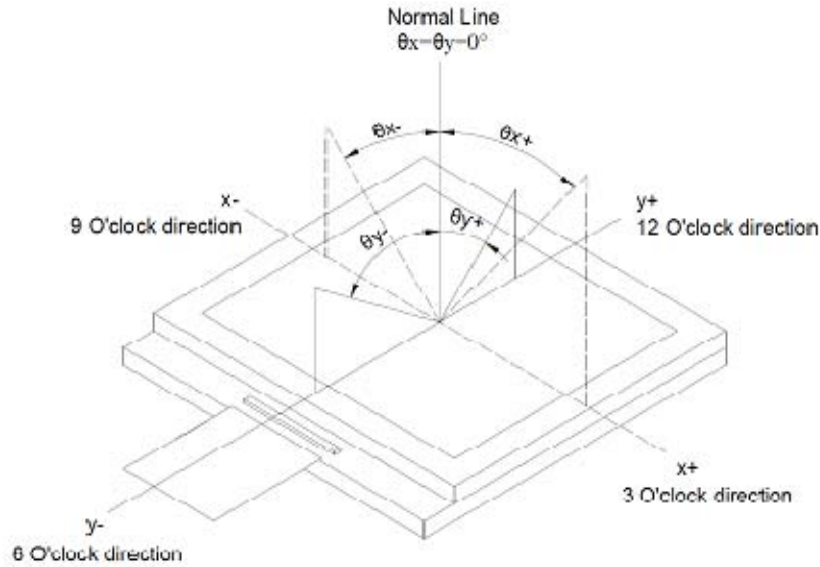

Note (2) Definition of Contrast Ratio(CR) :
measured at the center point of panel

$$\text{Contrast ratio (CR)} = \frac{\text{Photo detector output when LCD is at "White" state}}{\text{Photo detector output when LCD is at "Black"}}$$

Note (3) Definition of Response Time : Sum of TR and TF

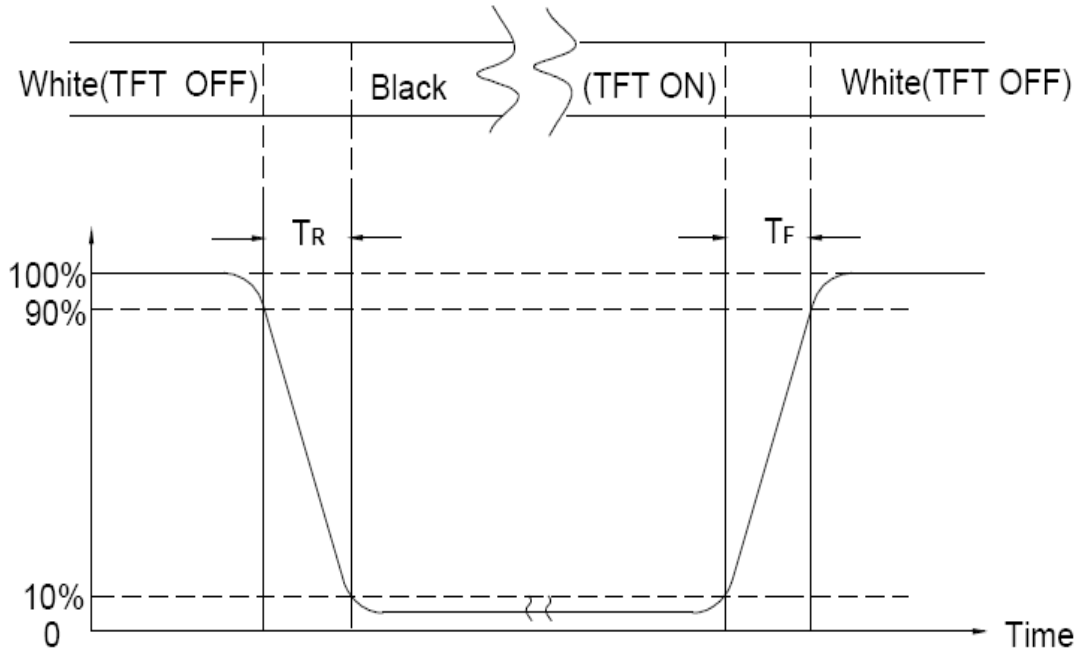

8. Interface Pin Assignment:

No.	Symbol	Function
1~2	LED-	Backlight LED Cathode input pin.
3~4	LED+	Backlight LED Anode input pin.
5	GND	Ground.
6	RESET	System reset pin.
7	NC	No connector.
8	NC	Dummy.
9	NC	
10	NC	
11	NC	
12~35	B00~B23	Data Bus.
36	HSYNC	Horizontal Synchronous signal.
37	VSYNC	Vertical Synchronous signal.
38	DCLK	Data clock.
39~40	NC	No connector.
41~42	VCC	Power supply.
43	SPENA	Chip select for serial port use.
44	GND	Ground.
45	NC	No connector.
46	GND	Ground.
47,48	NC	No connector.
49	SPCK	Serial port Clock.
50	SPDA	Serial port Data input/output
51	NC	No connector.
52	DEN	Data enable signal.
53~54	GND	Ground.

9. Block Diagram:

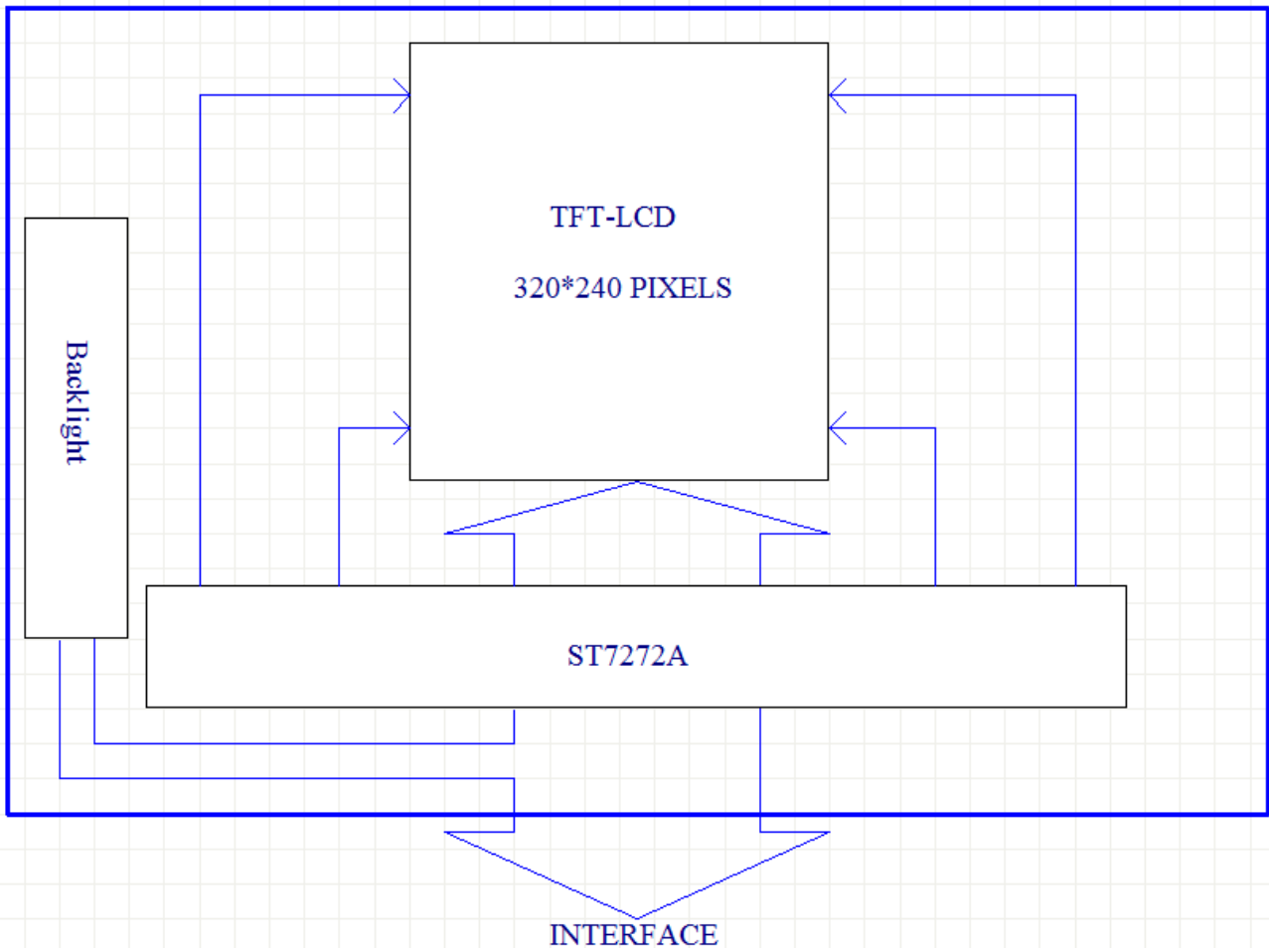

10. Backlight:

1. Standard Lamp Styles (Edge Lighting Type):
The LED chips are distributed over the edge light area of the illumination unit, which gives the less power consumption:
2. The Main Advantages of the LED Backlight are as following:
 - 2.1 The brightness of the backlight can simply be adjusted.
By a resistor or a potentiometer.

3. Data About LED Backlight:

($T_a=25^{\circ}\text{C}$)

PARAMETER	Sym.	Min.	Typ.	Max.	Unit	Test Condition	Note
Supply Current	I	20			mA	V=19.2V	
Supply Voltage	V	16.2	19.2	20.4	V	If=20mA	
Luminous Intensity for LCM	IV	420	600	-	cd/m ²		2
Uniformity for LCM	-	70	-	-	%		3
Life Time	-	20000	-	-	Hr.		4
Color	White						

NOTE:

1. Backlight Only
2. Average Luminous Intensity of P1-P9
3. Uniformity = Min/Max * 100%
4. LED life time defined as follows: The final brightness is at 50% of original brightness

Measured Method: (X*Y: Light Area)

Internal Circuit Diagram

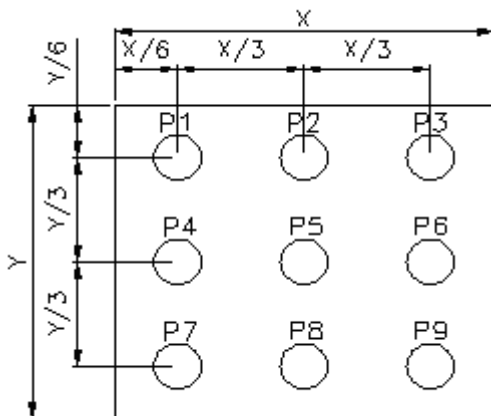

CIRCUIT DIAGRAM B/L Electrical Circuit

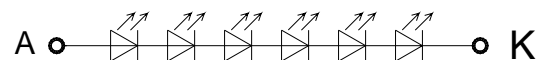

(Effective spatial Distribution)

Using aperture of 1° , distance 50cm

11. Standard Specification for Reliability:

11-1. Standard Specifications for Reliability of LCD Module

No	Item	Description
01	High temperature operation	The sample should be allowed to stand at 70°C for 120 hours under driving condition and then returning it to normal temperature condition, and allowing it stand for 2 hours.
02	Low temperature operation	The sample should be allowed to stand at -20°C for 120 hours under driving condition and then returning it to normal temperature condition, and allowing it stand for 2 hours.
03	High temperature storage	The sample should be allowed to stand at 80°C for 240 hours under no-load condition, and then returning it to normal temperature condition, and allowing it stand for 2 hours.
04	Low temperature storage	The sample should be allowed to stand at -30°C for 240 hours under no-load condition, then returning it to normal temperature condition, and allowing it stand for 2 hours.
05	Moisture storage	The sample should be allowed to stand at 60°C,90%RH MAX for 240 hours under no-load condition, then taking it out and drying it at normal temperature for 2 hours.
06	Thermal shock storage	The sample should be allowed to stand the following 10 cycles : -30°C for 30 minutes → normal temperature for 5 minutes → +80°C for 30 minutes → normal temperature for 5 minutes, as one cycle.
07	Packing vibration	Frequency range : 10Hz ~ 55Hz Amplitude of vibration : 1.5mm Sweep time: 12 min X,Y,Z 2 hours for each direction.
08	Packing drop test	According to ISTA 1A 2001.
09	Electrical Static Discharge	Air: ±4KV 150pF/330Ω 5 times
		Contact: ±2KV 150pF/330Ω 5 time

*Sample size for each test item is 3~5pcs

11 - 2. Testing Conditions and Inspection Criteria

For the final test the testing sample must be stored at room temperature for 24 hours, after the tests listed in Table 11.2, Standard specifications for Reliability have been executed in order to ensure stability.

No	Item	Test Model	In section Criteria
01	Current Consumption	Refer To Specification	The current consumption should conform to the product specification.
02	Contrast	Refer To Specification	After the tests have been executed, the contrast must be larger than half of its initial value prior to the tests.
03	Appearance	Visual inspection	Defect free.

11- 3. MTBF

MTBF	Functions, performance, appearance, etc. shall be free from remarkable deterioration within 50,000 hours under ordinary operating and storage conditions room temperature ($25\pm 5^{\circ}\text{C}$), normal humidity ($50\pm 10\%$ RH), and in area not exposed to direct sun light.
------	---

12. Specification of Quality Assurance:

12-1. Purpose

This standard for Quality Assurance should affirm the quality of LCD module products to supply to purchaser by YEEBO CORPORATION (Supplier).

12-2. Standard for Quality Test

a. Inspection:

Before delivering, the supplier should take the following tests, and affirm the quality of product.

b. Electro-Optical Characteristics:

According to the individual specification to test the product.

c. Test of Appearance Characteristics:

According to the individual specification to test the product.

d. Test of Reliability Characteristics:

According to the definition of reliability on the specification for testing products.

e. Delivery Test:

Before delivering, the supplier should take the delivery test.

(i) Test method: According to ISO2859-1.General Inspection Level II take a single time.

(ii) The defects classify of AQL as following:

Major defect: AQL = 0.65

Minor defect: AQL = 2.5

Total defects: AQL = 2.5

12-3. Non- conforming Analysis & Deal With Manners

a. Non- conforming Analysis:

(i) Purchaser should supply the detail data of non- conforming sample and the non-conforming.

(ii) After accepting the detail data from purchaser, the analysis of non- conforming should be finished in two weeks.

(iii) If supplier can not finish analysis on time, must announce purchaser before 3 days.

b. Disposition of non- conforming:

(i) If find any product defect of supplier during assembly time, supplier must change the good product for every defect after recognition.

(ii) Both supplier and customer should analyze the reason and discuss the disposition of non- conforming when the reason of nonconforming is not sure.

12-4. Agreement items

Both sides should discuss together when the following problems happen.

a. There is any problem of standard of quality assurance, and both sides should think that must be modified.

b. There is any argument item which does not record in the standard of quality assurance.

c. Any other special problem.

12-5. Standard of The Product Appearance Test

a. Manner of appearance test:

(i) The test must be under $20W \times 2$ or $40W$ fluorescent light, and the distance of view must be at $30 \pm 5cm$.

(ii) When test the model of transmissive product must add the reflective plate.

(iii) The test direction is base on around 10° of vertical line.

(iii) Temperature: $25 \pm 5^\circ C$ Humidity: $60 \pm 10\% RH$

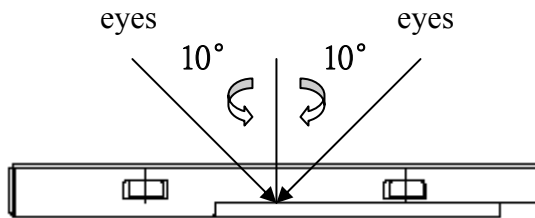

(iv) Definition of area:

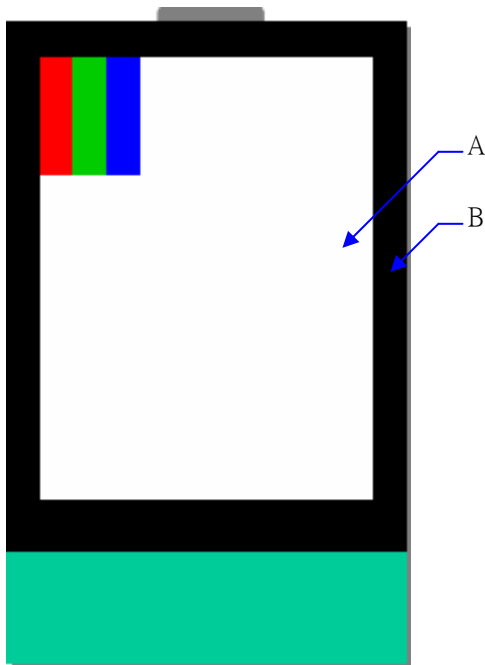

A. Area: Viewing area.

B. Area: Out of viewing area.

(Outside viewing area)

b. Basic principle:

(i) It will accord to the AQL when the standard can not be described.

(ii) The sample of the lowest acceptable quality level must be discussed by both supplier and customer when any dispute happened.

(iii) Must add new item on time when it is necessary.

c. Standard of inspection: (Unit: mm)

12-6. Inspection specification

Defect out of viewing area can be neglected.

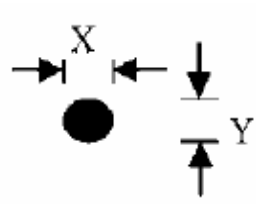
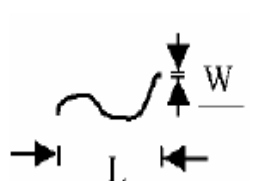
NO	Item	Criterion	AQL												
01	Electrical Testing	1.1 Missing vertical, horizontal segment, segment contrast defect. 1.2 Missing character, dot or icon. 1.3 Display malfunction. 1.4 No function or no display. 1.5 Current consumption exceeds product specifications. 1.6 LCD viewing angle defect. 1.7 Mixed product types. 1.8 Flicker	0.65												
02	Black or White spots or Bright spots or Color spots on LCD (Display only)	2.1 White and black or color spots on display $\leq 0.25\text{mm}$, no more than Five spots. 2.2 Densely spaced: No more than three spots within 3mm. 2.3 Not visible through 5% ND filter	2.5												
03	LCD and Touch Panel black spots, white spots, contamination (non – display)	3.1 Round type: As following drawing $\Phi = (X+Y) / 2$  <table border="1" data-bbox="861 1019 1396 1276"> <thead> <tr> <th>Size(mm)</th> <th>Acceptable Q'ty</th> </tr> </thead> <tbody> <tr> <td>$\Phi \leq 0.10$</td> <td>Accept no dense</td> </tr> <tr> <td>$0.10 < \Phi \leq 0.20$</td> <td>2</td> </tr> <tr> <td>$0.20 < \Phi \leq 0.25$</td> <td>2</td> </tr> <tr> <td>$0.25 < \Phi \leq 0.30$</td> <td>1</td> </tr> <tr> <td>$0.30 < \Phi$</td> <td>0</td> </tr> </tbody> </table> <p>* Densely spaced: No more than two spots within 3mm.</p>	Size(mm)	Acceptable Q'ty	$\Phi \leq 0.10$	Accept no dense	$0.10 < \Phi \leq 0.20$	2	$0.20 < \Phi \leq 0.25$	2	$0.25 < \Phi \leq 0.30$	1	$0.30 < \Phi$	0	2.5
		Size(mm)	Acceptable Q'ty												
$\Phi \leq 0.10$	Accept no dense														
$0.10 < \Phi \leq 0.20$	2														
$0.20 < \Phi \leq 0.25$	2														
$0.25 < \Phi \leq 0.30$	1														
$0.30 < \Phi$	0														
3.2 Line type: (As following drawing)  <table border="1" data-bbox="766 1422 1396 1702"> <thead> <tr> <th>Length(mm)</th> <th>Width(mm)</th> <th>Acceptable Q'ty</th> </tr> </thead> <tbody> <tr> <td>---</td> <td>$W \leq 0.02$</td> <td>Accept no dense</td> </tr> <tr> <td>$L \leq 3.0$</td> <td>$0.02 < W \leq 0.05$</td> <td rowspan="2">2</td> </tr> <tr> <td>$L \leq 2.5$</td> <td>$0.03 < W \leq 0.08$</td> </tr> <tr> <td>---</td> <td>$0.08 < W$</td> <td>Rejection</td> </tr> </tbody> </table> <p>* Densely spaced: No more than two lines within 3mm.</p>	Length(mm)	Width(mm)	Acceptable Q'ty	---	$W \leq 0.02$	Accept no dense	$L \leq 3.0$	$0.02 < W \leq 0.05$	2	$L \leq 2.5$	$0.03 < W \leq 0.08$	---	$0.08 < W$	Rejection	2.5
Length(mm)	Width(mm)	Acceptable Q'ty													
---	$W \leq 0.02$	Accept no dense													
$L \leq 3.0$	$0.02 < W \leq 0.05$	2													
$L \leq 2.5$	$0.03 < W \leq 0.08$														
---	$0.08 < W$	Rejection													

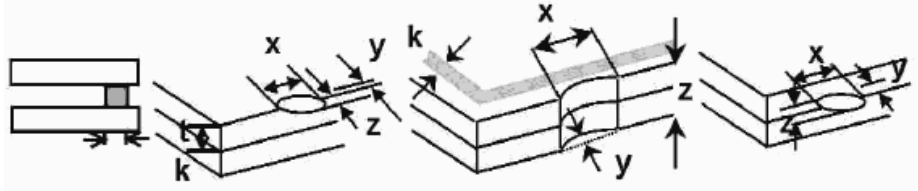
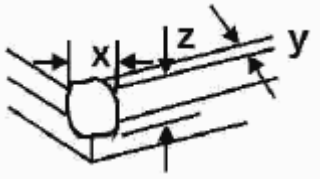
NO	Item	Criterion	AQL																		
04	Polarizer bubbles	<p>If bubbles are visible, judge using black spot specifications, not easy to find, must check in specify direction</p> <table border="1"> <thead> <tr> <th>Size Φ(mm)</th> <th>Acceptable Q'ty</th> </tr> </thead> <tbody> <tr> <td>$\Phi \leq 0.20$</td> <td>Accept no dense</td> </tr> <tr> <td>$0.20 < \Phi \leq 0.50$</td> <td>3</td> </tr> <tr> <td>$0.50 < \Phi \leq 1.00$</td> <td>2</td> </tr> <tr> <td>$1.00 < \Phi$</td> <td>0</td> </tr> <tr> <td>Total Q'ty</td> <td>3</td> </tr> </tbody> </table>	Size Φ (mm)	Acceptable Q'ty	$\Phi \leq 0.20$	Accept no dense	$0.20 < \Phi \leq 0.50$	3	$0.50 < \Phi \leq 1.00$	2	$1.00 < \Phi$	0	Total Q'ty	3	2.5						
Size Φ (mm)	Acceptable Q'ty																				
$\Phi \leq 0.20$	Accept no dense																				
$0.20 < \Phi \leq 0.50$	3																				
$0.50 < \Phi \leq 1.00$	2																				
$1.00 < \Phi$	0																				
Total Q'ty	3																				
05	Scratches	Follow NO.3 -2 Line Type.																			
06	Mura	Not visible through 5% ND filter in 50% gray.	2.5																		
07	Chipped glass	<p>Symbols: x: Chip length y: Chip width z: Chip thickness k: Seal width t: Glass thickness a: LCD side length L: Electrode pad length</p> <p>6.1 General glass chip: 6.1.1 Chip on panel surface and crack between panels:</p>  <table border="1"> <thead> <tr> <th>z: Chip thickness</th> <th>y: Chip width</th> <th>x: Chip length</th> </tr> </thead> <tbody> <tr> <td>$Z \leq 1/2t$</td> <td>Not over viewing area</td> <td>$x \leq 1/8a$</td> </tr> <tr> <td>$1/2t < z \leq 2t$</td> <td>Not exceed 1/3k</td> <td>$x \leq 1/8a$</td> </tr> </tbody> </table> <p>⊙ Unit: mm ⊙ If there are 2 or more chips, x is the total length of each chip</p> <p>6.1.2 Corner crack:</p>  <table border="1"> <thead> <tr> <th>z: Chip thickness</th> <th>y: Chip width</th> <th>x: Chip length</th> </tr> </thead> <tbody> <tr> <td>$Z \leq 1/2t$</td> <td>Not over viewing area</td> <td>$x \leq 1/8a$</td> </tr> <tr> <td>$1/2t < z \leq 2t$</td> <td>Not exceed 1/3k</td> <td>$x \leq 1/8a$</td> </tr> </tbody> </table> <p>⊙ Unit: mm ⊙ If there are 2 or more chips, x is the total length of each chip</p>	z: Chip thickness	y: Chip width	x: Chip length	$Z \leq 1/2t$	Not over viewing area	$x \leq 1/8a$	$1/2t < z \leq 2t$	Not exceed 1/3k	$x \leq 1/8a$	z: Chip thickness	y: Chip width	x: Chip length	$Z \leq 1/2t$	Not over viewing area	$x \leq 1/8a$	$1/2t < z \leq 2t$	Not exceed 1/3k	$x \leq 1/8a$	2.5
z: Chip thickness	y: Chip width	x: Chip length																			
$Z \leq 1/2t$	Not over viewing area	$x \leq 1/8a$																			
$1/2t < z \leq 2t$	Not exceed 1/3k	$x \leq 1/8a$																			
z: Chip thickness	y: Chip width	x: Chip length																			
$Z \leq 1/2t$	Not over viewing area	$x \leq 1/8a$																			
$1/2t < z \leq 2t$	Not exceed 1/3k	$x \leq 1/8a$																			

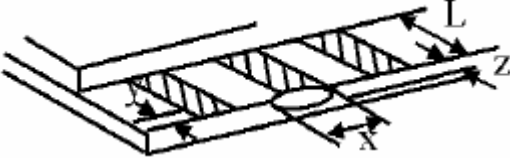
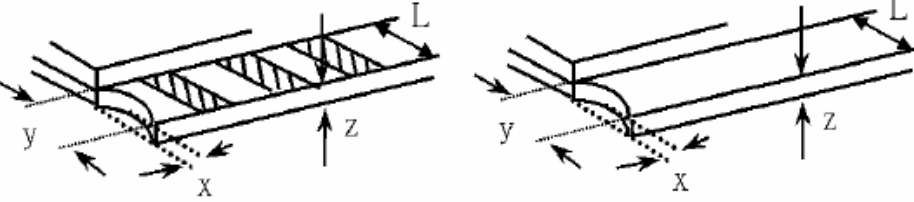
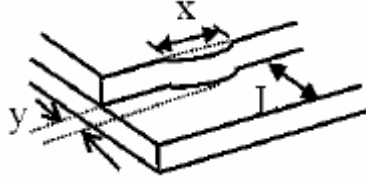
NO	Item	Criterion	AQL																
08	Glass crack	<p>Symbols: x: Chip length y: Chip width z: Chip thickness k: Seal width t: Glass thickness a: LCD side length L: Electrode pad length</p> <p>7.2 Protrusion over terminal: 7.2.1 Chip on electrode pad:</p>  <table border="1" data-bbox="582 683 1257 828"> <tr> <td>y: Chip width</td> <td>x: Chip length</td> <td>z: Chip thickness</td> </tr> <tr> <td>$y \leq 0.5\text{mm}$</td> <td>$x \leq 1/8a$</td> <td>$0 < z \leq t$</td> </tr> </table> <p>7.2.2 Non-conductive portion:</p>  <table border="1" data-bbox="582 1198 1257 1344"> <tr> <td>y: Chip width</td> <td>x: Chip length</td> <td>z: Chip thickness</td> </tr> <tr> <td>$y \leq L$</td> <td>$x \leq 1/8a$</td> <td>$0 < z \leq t$</td> </tr> </table> <p>⊙ If there chipped area touches the ITO terminal, over 2/3 of the ITO must remain and be inspected according to electrode terminal specifications. ⊙ If the product will be heat sealed by the customer, the alignment mark must not be damaged.</p> <p>7.2.3 Substrate protuberance and internal crack</p>  <table border="1" data-bbox="901 1668 1337 1814"> <tr> <td>y: width</td> <td>x: length</td> </tr> <tr> <td>$y \leq 1/3L$</td> <td>$X \leq a$</td> </tr> </table>	y: Chip width	x: Chip length	z: Chip thickness	$y \leq 0.5\text{mm}$	$x \leq 1/8a$	$0 < z \leq t$	y: Chip width	x: Chip length	z: Chip thickness	$y \leq L$	$x \leq 1/8a$	$0 < z \leq t$	y: width	x: length	$y \leq 1/3L$	$X \leq a$	2.5
y: Chip width	x: Chip length	z: Chip thickness																	
$y \leq 0.5\text{mm}$	$x \leq 1/8a$	$0 < z \leq t$																	
y: Chip width	x: Chip length	z: Chip thickness																	
$y \leq L$	$x \leq 1/8a$	$0 < z \leq t$																	
y: width	x: length																		
$y \leq 1/3L$	$X \leq a$																		

NO	Item	Criterion	AQL
09	Cracked glass	The LCD with extensive crack is not acceptable.	2.5
10	Backlight elements	9.1 Illumination source flickers when lit. 9.2 Spots or scratches that appear when lit must be judged. Using LCD spot, lines and contamination standards. 9.3 Backlight doesn't light or color is wrong.	2.5 2.5 0.65
11	Bezel	Bezel must comply with product specifications.	2.5
12	PCB、COB	11.1 COB seal may not have pinholes larger than 0.2mm or contamination. 11.2 COB seal surface may not have pinholes through to the IC. 11.3 The height of the COB should not exceed the height indicated in the assembly diagram. 11.4 There may not be more than 2mm of sealant outside the seal area on PCB. And there should be no more than three places. 11.5 Parts on PCB must be the same as on the production characteristic chart, There should be no wrong parts, missing parts or excess parts. 11.6 The jumper on the PCB should conform to the product characteristic chart.	2.5 2.5 2.5 2.5 0.65 0.65
13	FPC	12.1 FPC terminal damage \leq 1/2 FPC terminal width and can not affect the function , we judge accept. 12.2 FPC alignment hole damage \leq 1/2 alignment area and can not affect the function , we judge accept.	2.5 2.5
14	Soldering	13.1 No cold solder joints, missing solder connections, oxidation or icicle. 13.2 No short circuits in components on PCB or FPC.	2.5 0.65

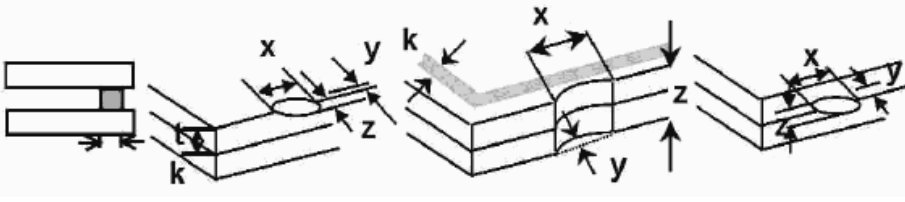
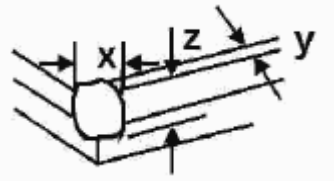
NO	Item	Criterion	AQL												
15	Touch Panel Chipped glass	<p>Symbols: x: Chip length y: Chip width z: Chip thickness k: Seal width t: Touch Panel Total thickness a: LCD side length L: Electrode pad length</p> <p>14.1 General glass chip: 14.1.1 Chip on panel surface and crack between panels:</p>  <table border="1" data-bbox="375 761 1193 981"> <tr> <td>z: Chip thickness</td> <td>y: Chip width</td> <td>x: Chip length</td> </tr> <tr> <td>$Z \leq t$</td> <td>$\leq 1/2 k$ and not over viewing area</td> <td>$x \leq 1/8a$</td> </tr> </table> <p>⊙ Unit: mm ⊙ If there are 2 or more chips, x is the total length of each chip</p> <p>14.1.2 Corner crack:</p>  <table border="1" data-bbox="375 1355 1193 1574"> <tr> <td>z: Chip thickness</td> <td>y: Chip width</td> <td>x: Chip length</td> </tr> <tr> <td>$z \leq t$</td> <td>$\leq 1/2 k$ and not over viewing area</td> <td>$x \leq 1/8a$</td> </tr> </table> <p>⊙ Unit: mm ⊙ If there are 2 or more chips, x is the total length of each chip</p>	z: Chip thickness	y: Chip width	x: Chip length	$Z \leq t$	$\leq 1/2 k$ and not over viewing area	$x \leq 1/8a$	z: Chip thickness	y: Chip width	x: Chip length	$z \leq t$	$\leq 1/2 k$ and not over viewing area	$x \leq 1/8a$	2.5
z: Chip thickness	y: Chip width	x: Chip length													
$Z \leq t$	$\leq 1/2 k$ and not over viewing area	$x \leq 1/8a$													
z: Chip thickness	y: Chip width	x: Chip length													
$z \leq t$	$\leq 1/2 k$ and not over viewing area	$x \leq 1/8a$													

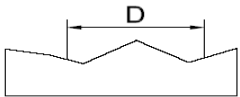
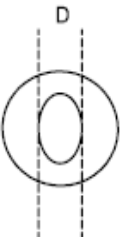
NO	Item	Criterion	AQL										
16	Touch Panel(Fish eye、dent and bubble on film)	<table border="1"> <thead> <tr> <th>SIZE(mm)</th> <th>Acceptable Q'ty</th> </tr> </thead> <tbody> <tr> <td>$\Phi \leq 0.2$</td> <td>Accept no dense</td> </tr> <tr> <td>$0.2 < D \leq 0.4$</td> <td>5</td> </tr> <tr> <td>$0.4 < D \leq 0.5$</td> <td>2</td> </tr> <tr> <td>$0.5 < D$</td> <td>0</td> </tr> </tbody> </table>  	SIZE(mm)	Acceptable Q'ty	$\Phi \leq 0.2$	Accept no dense	$0.2 < D \leq 0.4$	5	$0.4 < D \leq 0.5$	2	$0.5 < D$	0	2.5
SIZE(mm)	Acceptable Q'ty												
$\Phi \leq 0.2$	Accept no dense												
$0.2 < D \leq 0.4$	5												
$0.4 < D \leq 0.5$	2												
$0.5 < D$	0												
17	Touch Panel Newton ring	Newton ring dimension $\leq 1/2$ touch panel area and not affect font and line distortion($\leq 2.5\%$), it is acceptable.	2.5										
18	Touch Panel Linearity	Less than 2.5% is acceptable.	2.5										
19	LCD Ripple	Touch the touch panel , can not see the LCD ripple. Pen: R 1.0mm silicon rubber. Operation Force: 80g	2.5										
20	General appearance	19.1 Pin type must match type in specification sheet. 19.2 LCD pin loose or missing pins. 19.3 Product packaging must the same as specified on packaging specification sheet. 19.4 Product dimension and structure must conform to product specification sheet.	0.65 0.65 0.65 0.65										

13. Handling Precaution:

13-1 Handling of LCM

- Don't give external shock.
- Don't apply excessive force on the surface.
- Liquid in LCD is hazardous substance. Must not lick and swallow. when the liquid is attach to your hand, skin, cloth etc. Wash it out thoroughly and immediately.
- Don't operate it above the absolute maximum rating.
- Don't disassemble the LCM.
- The operators should be grounded whenever he/she comes into contact with the module. Never touch any of the conductive parts such as the LSI pads, the copper leads on the PCB and the interface terminals with any parts of the human body.
- The modules should be kept in antistatic bags or other containers resistant to static for storage.
- The module is coated with a film to protect the display surface. Be care when peeling off this protective film since static electricity may be generated.

13-2 Storage

- Store in an ambient temperature of $25\pm 10^{\circ}\text{C}$, and in a relative humidity of $50\pm 10\%\text{RH}$. Don't expose to sunlight or fluorescent light.
- Storage in a clean environment, free from dust, active gas, and solvent.
- Store in anti-static electricity container.
- Store without any physical load.

13-3 Soldering

- Use only soldering irons with proper grounding and no leakage.
- Iron: No higher than $280\pm 10^{\circ}\text{C}$ and less than 3 sec during Hand soldering.
- Rewiring: no more than 2 times.

14. Guarantee:

Our products could meet requirements of the environment.
YB's RoHS is introduce European Union Directive 2011/65/EU (ROHS)
Requirements and Update.