

SPECIFICATION FOR LCD MODULE

MODULE NO: YB-TG19201080S02A-C-A1

Doc.Version:07

Customer Approval:

<input type="checkbox"/> Accept	<input type="checkbox"/> Reject
---------------------------------	---------------------------------

YEEBO	NAME	SIGNATURE	DATE
Prepare	Electronic Engineer	何康宇	2020/7/21
Check	Mechanical Engineer	孙玉南	2020/7/21
Verify		陈长吉	2020/7/21
Approval		孙玉南	2020/7/21

- APPROVAL FOR SPECIFICATIONS ONLY
- APPROVAL FOR SPECIFICATIONS AND SAMPLE

WIMRD005-02-C

2. Table of Contents:

NO	CONTENTS	PAGE
1	Revision History	1
2	Table of Contents	2
3	Module Numbering System	3
4	General Specification	4
5	LCM drawing	5
6	Integration Interface Requirement	6
7	Electrical Characteristics	12
8	Optical Specifications	16
9	Reliability Test Items	21
10	Specification of Quality Assurance	23
11	Handing Precaution	31
12	Guarantee	31

3. Module Numbering System:

(Example)

YB- TG 19201080 S 02 A -C - A1

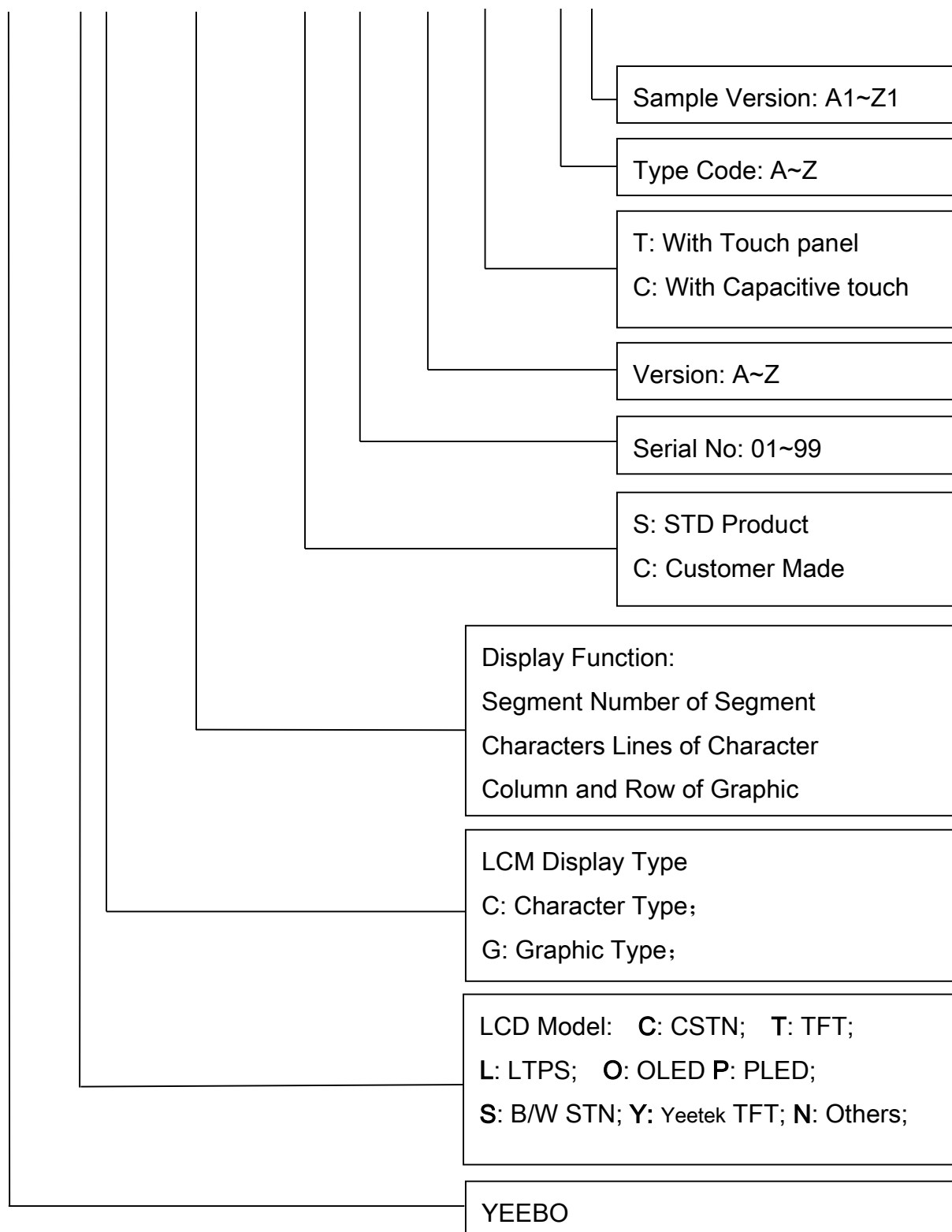

4. General Specification:

ITEM	CONTENTS
Assembly Module Size	334.70(W) * 209.10(H) * 4.29(T) mm
Display Size(Diagonal)	13.3 inch
Display Format	1920*3(RGB)*1080 Pixels
Active Area	293.47(W) * 165.08(H) mm
Pixel Pitch	0.1529 * 0.1529 mm
LCD Type	Normally black
White Luminance (I _{LED} =24mA) (Note: I _{LED} is LED current)	345typ. (5 points average) 275 min.(5 points average) [cd/m ²]
Surface treatment	Anti-Glare
Color arrangement	R.G.B. Vertical Stripe
TFT interface	2 Lane eDP 1.2
Contrast Ratio	800 typ
View Direction	ALL
CTP IC	ILI2510
CTP Interface	USB(The reserved I ² C)
Weight(g)	≈444.5g
Firmware	ILI2510_8987_20190216.hex
Test Configuration	8987_20190216.dat

5. CTP+LCM drawing:

Count drawing & Spec revision record during discussion with customer		
Rev	Revision content description	Date
#1	FIRST ISSUE	2018-10-31
#2	Change connector model and PIN definition	2018-12-18
#3	Change operating temperature and storage temperature	2019-01-11
#4	Increase the spurt the code	2019-04-09
#5	Update PIN order	2020-07-08
#6	Change PIN voltage	2020-07-21

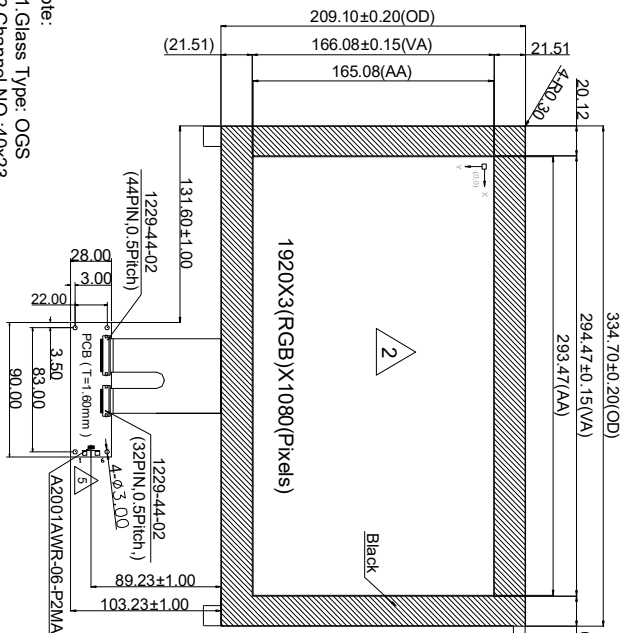

- Note:
1. Glass Type: OGS
 2. Channel NO.: 40X23
 3. TP Controller IC: ILI2510
 4. Transmittance Rate: $\geq 86\%$
 5. Pixels HxV: 1920X3 (RGB) X1080
 6. White Luminance (LED=24mA)
410typ. (5 points average)
325min. (5 points average)
 7. Contrast Ratio: 800typ
 8. Pixel Pitch: 0.1529x0.1529
 9. Pixel Format: RGB Vertical Stripe
 10. Operating temperature: 0°C ~ +50°C
 11. Storage temperature: -20°C ~ +60°C
 12. Unspecified tolerance: $\pm 0.30\text{mm}$.
 13. ROHS Compliant

TP INK CODE NOTES:
YB-TG19201080S02A-C-A — Yeebo CTP+TFT
XXXX/XXXXXXXXXX
LOT NO.
Production Year and week

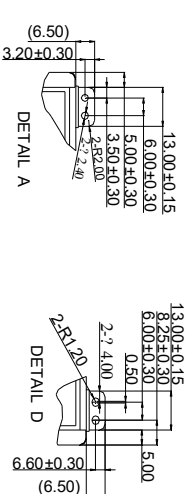
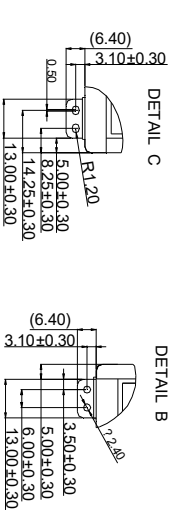

NO.	SYMBOL	PIN Assignment
1	VBUSIN(5.0V)	
2	GND	
3	DP	
4	GND	
5	DN	
6	GND	

FPC PIN OUT	
1	NC
2	GND
3	Label N
4	Label I P
5	GND
6	Label N
7	Label P
8	GND
9	AUX CH P
10	AUX CH N
11	GND
12	VCC
13	VCC
14	LCID Sd/Tst on NC
15	GND
16	GND
17	HPD
18	BI_GND
19	BI_GND
20	BI_GND
21	BI_GND
22	BI_ENABLE
23	BI_PWM
24	H_SYNC on NC
25	NC/Reserved
26	VLED
27	VLED
28	VLED
29	VLED
30	NC

Customer Approval

		MOD. Name	YB-TG19201080S02A-C-A			FILE NAME	Count Dwg.
		DESIGNED	CHECKED	VERIFIED	APPROVED		
UNIT	SIZE	SCALE					
mm	A4	N-T-S					
Sheet	1						
Of	1						

6. Integration Interface Requirement

6-1 Connector Description

Physical interface is described as for the connector on module.

These connectors are capable of accommodating the following signals and will be following components.

Connector Name / Designation	For Signal Connector
Manufacturer	IPEX or compatible
Type / Part Number	IPEX 20455-030E-12 or compatible (0.5mm pitch or compatible)
Mating Housing/Part Number	IPX or compatible

6-2 Pin Assignment (with Touch Sensor Pin Assignment)

Pin	Symbol	Description
1	NC Reserved	Reserved for LCD supplier
2	GND	High Speed Ground
3	Lane1_N	Complement Signal Link Lane 1
4	Lane1_P	True Signal Link Lane 1
5	GND	High Speed Ground
6	Lane0_N	Complement Signal Link Lane 0
7	Lane0_P	True Signal Link Lane 0
8	GND	High Speed Ground
9	AUX_CH_P	True Signal Auxiliary Channel
10	AUX_CH_N	Complement Signal Auxiliary Channel
11	GND	High Speed Ground
12	VCC	LCD logic
13	VCC	LCD logic
14	LCD Self Test or NC	LCD Panel Self Test Enable (Optional)
15	GND	LCD logic and driver ground
16	GND	LCD logic and driver ground
17	HPD	HPD signale pin
18	BL_GND	LED Backlight ground
19	BL_GND	LED Backlight ground
20	BL_GND	LED Backlight ground
21	BL_GND	LED Backlight ground
22	BL ENABLE	LED Backlight control on/off control
23	BL PWM	System PWM signal input for dimming
24	H_SYNC or NC	H_SYNC function(Optional) or NC
25	NC Reserved	Reserved for LCD supplier
26	VLED	LED Backlight Power (5-21V)
27	VLED	LED Backlight Power (5-21V)
28	VLED	LED Backlight Power (5-21V)
29	VLED	LED Backlight Power (5-21V)
30	NC	NC

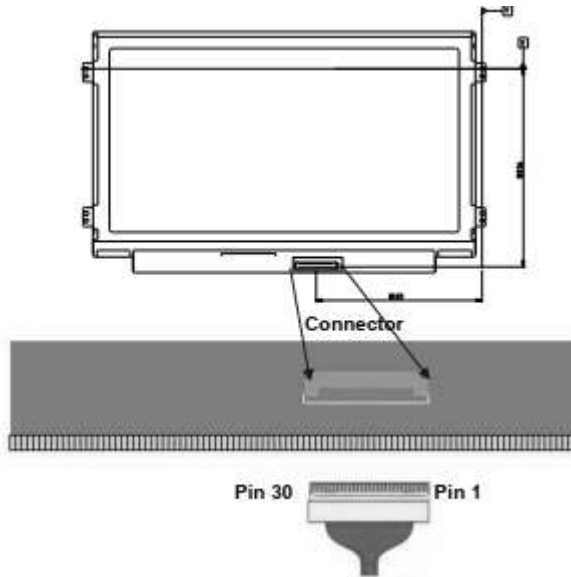

note1: Start from right side.
note2: Input signals shall be low or High-impedance state when VDD is off.
Internal circuit of eDP inputs are as following.

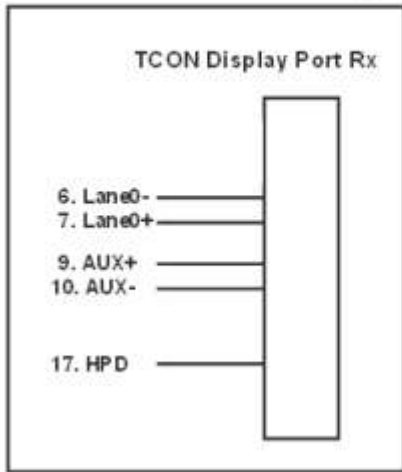

6-3 . Interface Timing

6.3.1 Timing Characteristics

Basically, interface timings should match the 1920x1080 /60Hz manufacturing guide line timing.

Parameter	Symbol	Min.	Typ.	Max.	Unit	
Frame Rate	-		60	-	Hz	
Clock frequency	$1/ T_{Clock}$	66.6	72	80	MHz	
Vertical Section	Period	T_V	1090	1116	1080+A	T_{Line}
	Active	T_{VD}	1080			
	Blanking	T_{VB}	10	36	A	
Horizontal Section	Period	T_H	1000	1052	960+B	T_{Clock}
	Active	T_{HD}	960			
	Blanking	T_{HB}	40	92	B	

Note 1 : The above is as optimized setting

Note 2 : The maximum clock frequency = $(1920+B)*(1080+A)*60 < 149.1$ MHz

6.3.2 Timing diagram

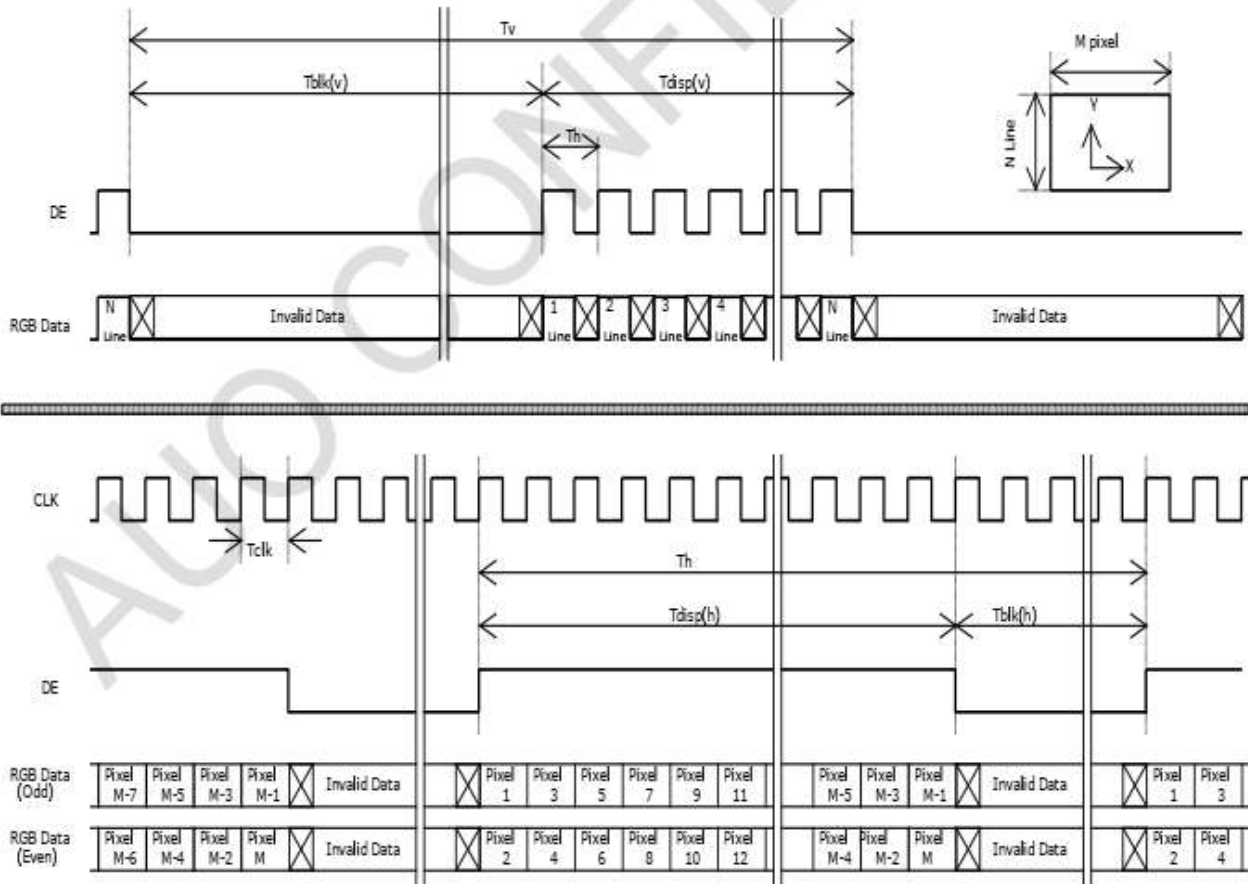

6.4 Power ON/OFF Sequence

Power on/off sequence is as follows. Interface signals and LED on/off sequence are also shown in the chart. Signals from any system shall be Hi-Z state or low level when VDD is off

Display Port panel power sequence:

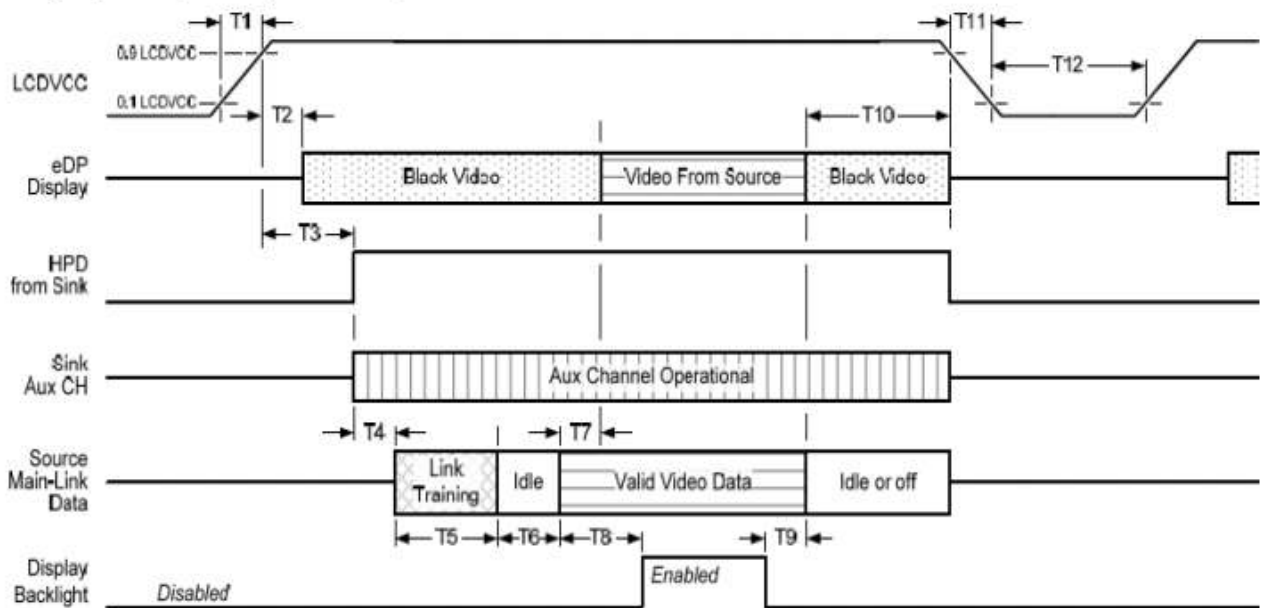

Display port interface power up/down sequence, normal system operation

Display Port AUX_CH transaction only:

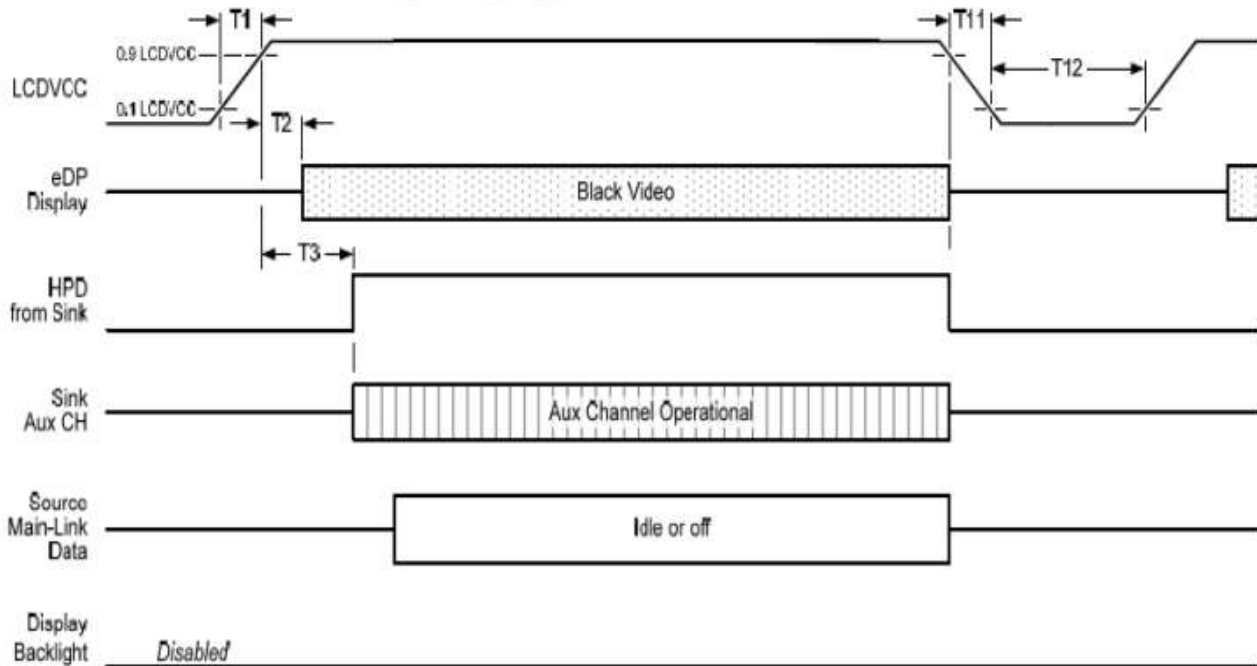

Display port interface power up/down sequence, AUX_CH transaction only

Display Port panel power sequence timing parameter:

Timing parameter	Description	Reqd. by	Limits			Notes
			Min.	Typ.	Max.	
T1	power rail rise time, 10% to 90%	source	0.5ms		10ms	
T2	delay from LCDVDD to black video generation	sink	0ms		200ms	prevents display noise until valid video data is received from the source
T3	delay from LCDVDD to HPD high	sink	0ms		200ms	sink AUX_CH must be operational upon HPD high.
T4	delay from HPD high to link training initialization	source				allows for source to read link capability and initialize.
T5	link training duration	source				dependant on source link to read training protocol.
T6	link idle	source				Min accounts for required BS-Idle pattern. Max allows for source frame synchronization.
T7	delay from valid video data from source to video on display	sink	0ms		50ms	max allows sink validate video data and timing.
T8	delay from valid video data from source to backlight enable	source				source must assure display video is stable.
T9	delay from backlight disable to end of valid video data	source				source must assure backlight is no longer illuminated.
T10	delay from end of valid video data from source to power off	source	0ms		500ms	
T11	power rail fall time, 90% to 10%	source			10ms	
T12	power off time	source	500ms			

Note1: The sink must include the ability to generate black video autonomously. The sink must automatically enable black video under the following conditions:

- upon LCDVDD power on (with in T2 max)-when the "Novideostream_Flag" (VB-ID Bit 3) is received from the source (at the end of T9).
- when no main link data, or invalid video data, is received from the source. Black video must be displayed within 64ms (typ) from the start of either condition. Video data can be deemed invalid based on MSA and timing information, for example.

Note 2: The sink may implement the ability to disable the black video function, as described in Note 1, above, for system development and debugging purpose.

Note 3: The sink must support AUX_CH polling by the source immediately following LCDVDD power on without causing damage to the sink device (the source can re-try if the sink is not ready). The sink must be able to respond to an AUX_CH transaction with the time specified within T3 max.

Display Port panel B/L power sequence timing parameter:

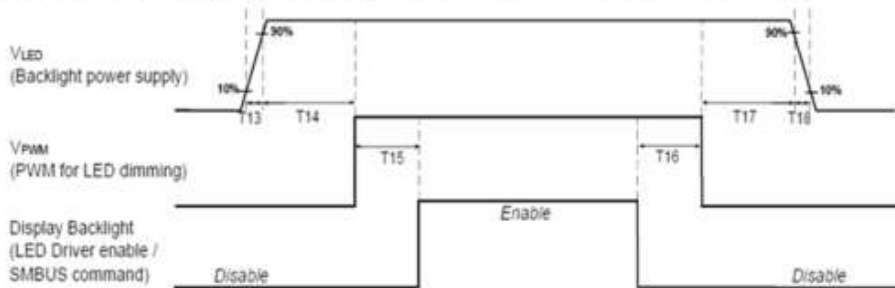

	Min (ms)	Max (ms)
T13	0.2	10
T14	0	-
T15	0	-
T16	0	-
T17	0	-
T18	0.2	10
T19	1 [*]	-
T20	1 [*]	-

Note : When the adapter is hot plugged, the backlight power supply sequence is shown as below.

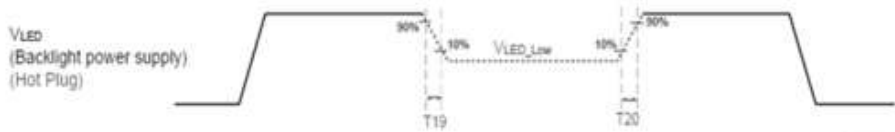

Seamless change: $T_{19}/T_{20} = 5 \times T_{PWM}^*$

* $T_{PWM} = 1/PWM \text{ Frequency}$

Note 1 : If T14,T15,T16,T17<10ms · The display garbage may occur. We suggest T14,T15,T16,T17>10ms to avoid the display garbage.

Note 2 : If T13 or T18<0.5ms · the inrush current may cause the damage of fuse. If T13 or T18<0.5ms · the inrush current I^2t is under typical melt of fuse Spec. · there is no mentioned problem.

Touch Panel Power on Sequence

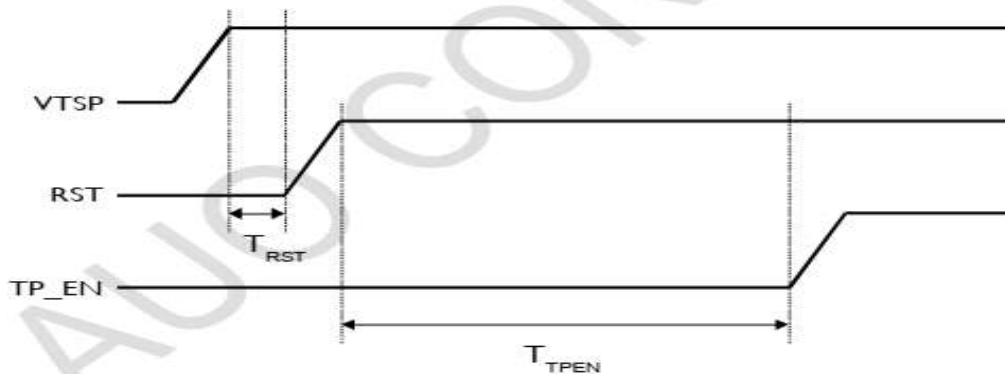

Timing	Description	Min (ms)
T _{RST}	Reset signal delay time from VTSP (TP power)	1
T _{TPEN}	TP enable signal delay time from reset signal	20



6-5. CTP Pin Assignment

Pin No.	Symbol	I/O	Function
1	VBUSIN	P	USB Supply Power
2	GND	P	Ground
3	DP	I/O	USB Data Positive
4	GND	P	Ground
5	DN	I/O	USB Data Positive
6	GND	P	Ground

7. Electrical Characteristics

7.1 TFT LCD Module

Table 7-1: TFT LCD Module

Input power specifications are as follows;

The power specification are measured under 25°C and frame frequency under 60Hz

Symble	Parameter	Min	Typ	Max	Units	Note
VDD	Logic/LCD Drive Voltage	3.0	3.3	3.6	[Volt]	
PDD	VDD Power	-	-	0.8	[Watt]	Note 1
IDD	IDD Current	-	-	267	[mA]	Note 1
IRush	Inrush Current	-	-	2000	[mA]	Note 2
VDDrp	Allowable Logic/LCD Drive Ripple Voltage	-	-	100	[mV] p-p	

Note 1 : Maximum Measurement Condition : Mosaic pattern at 3.3V driving voltage. ($P_{max} = V_{3.3} \times I_{white}$)

Note 2 : Measure Condition

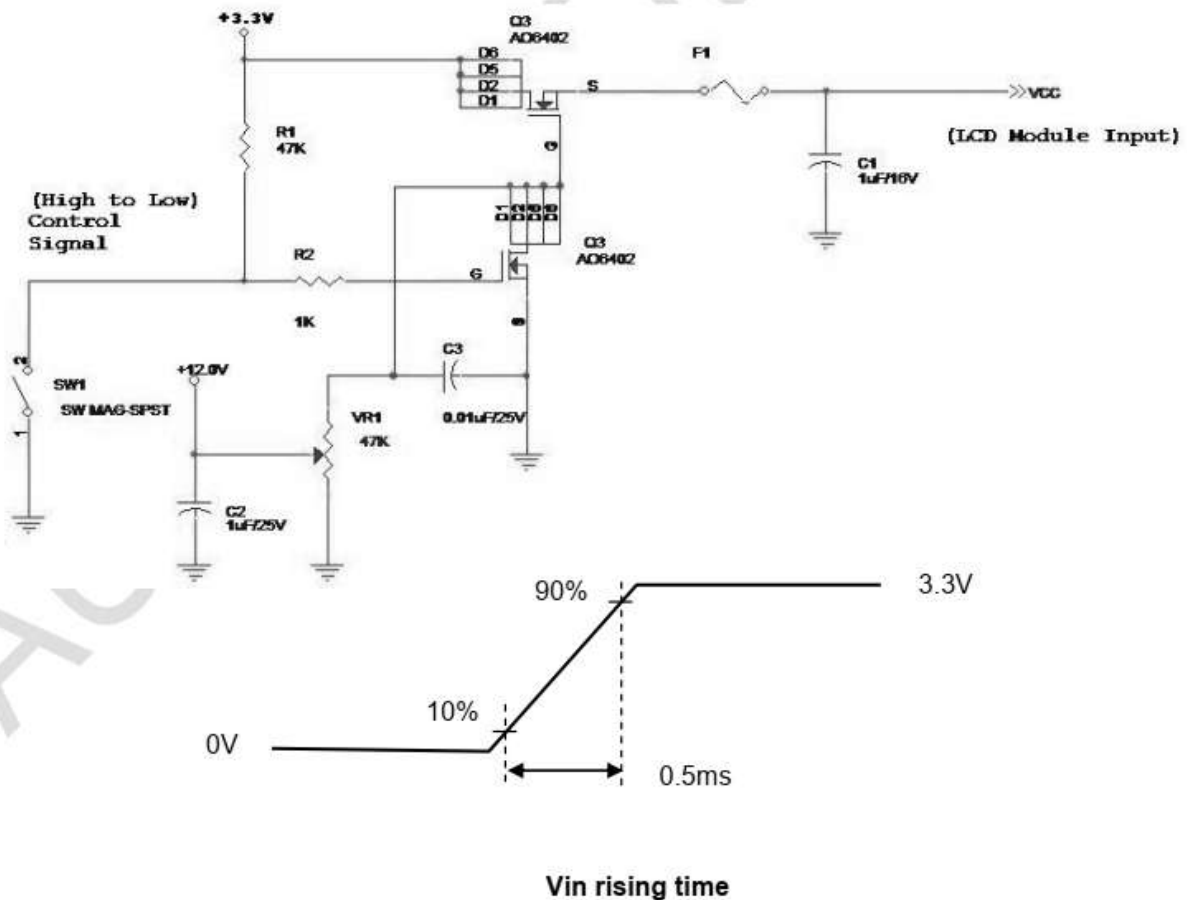

7.2 Signal Electrical Characteristics

Display port main link					
		Min	Typ	Max	unit
VCM	RX input DC Common Mode Voltage		0		V
VDiff _{P-P}	Peak-to-peak Voltage at a receiving Device	150		1320	mV

Follow as VESA display port standard V1.3

Display Port AUX_CH signal:

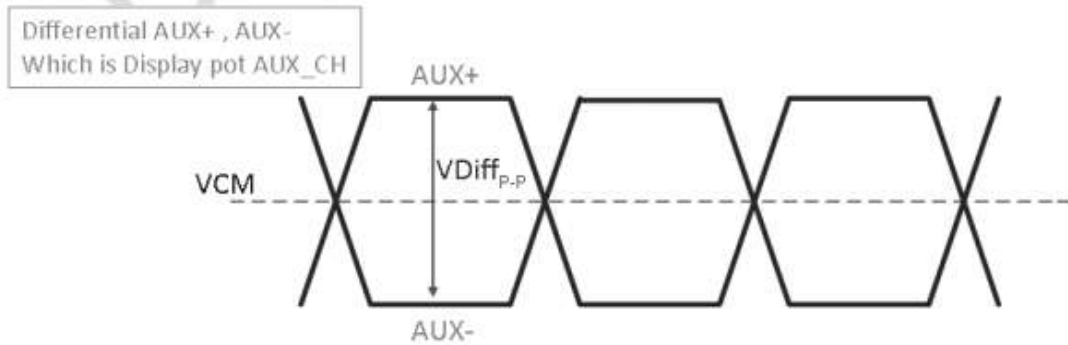

Signal electrical characteristics are as follows;

Display Port main link signal:

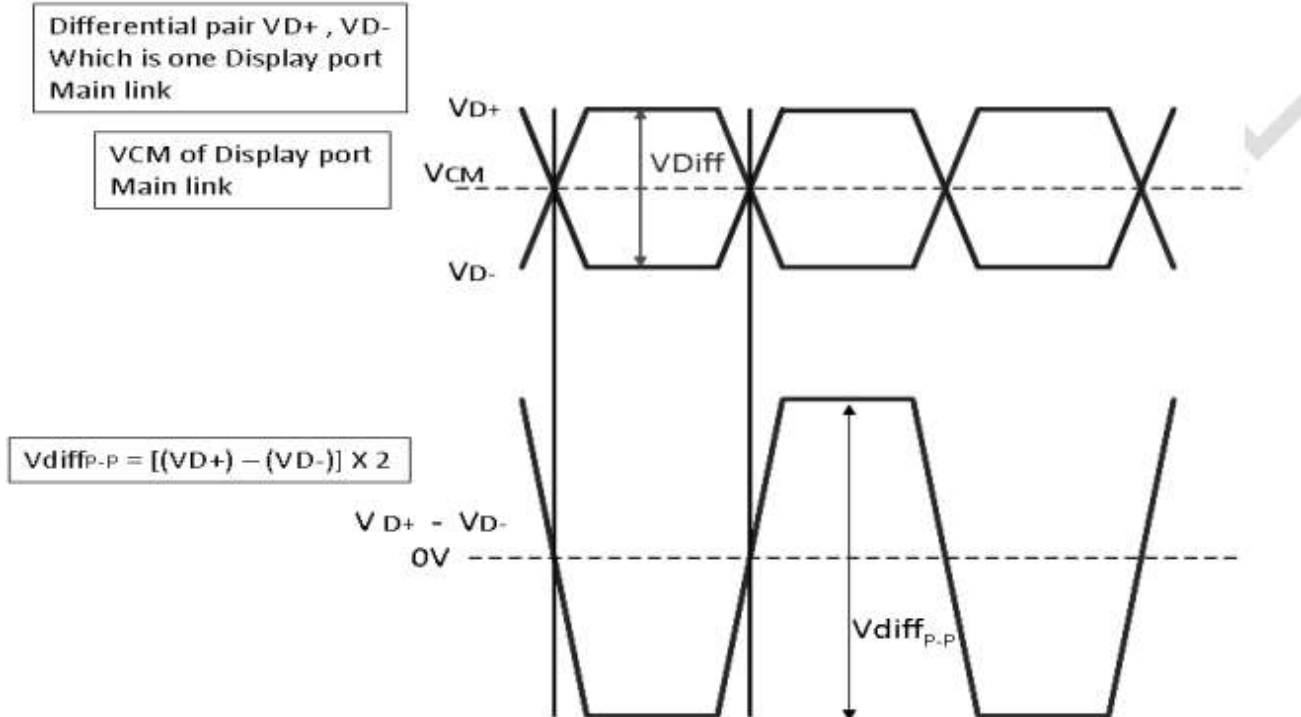

Display port AUX_CH					
		Min	Typ	Max	unit
VCM	AUX DC Common Mode Voltage		0		V
VDiff _{P,P}	AUX Peak-to-peak Voltage at a receiving Device	270		800	mV

Follow as VESA display port standard V1.3

Display Port VHPD signal:

Display port VHPD					
		Min	Typ	Max	unit
VHPD	HPD Voltage	2.25	-	3.6	V

Follow as VESA display port standard V1.3

7.3 Backlight Unit

Table 7-3-1: LED characteristics

Parameter	Symbol	Min	Typ	Max	Units	Condition
Backlight Power Consumption	PLED	-	-	2.4	[Watt]	(Ta=25°C), Note 1
LED Life-Time	N/A	15,000	-	-	Hour	(Ta=25°C), Note 2 I _p =24 mA

Note 1: Calculator value for reference $P_{LED} = V_F$ (Normal Distribution) * I_F (Normal Distribution) / Efficiency

Note 2: The LED life-time define as the estimated time to 50% degradation of initial luminous.

Table 7-3-2: Backlight input signal characteristics

Parameter	Symbol	Min	Typ	Max	Units	Remark
LED Power Supply	VLED (Note 1)	5.0 (Note 2)	12.0	21.0	[Volt]	Define as Connector Interface (Ta=25°C)
LED Enable Input High Level	VLED_EN	2.2	-	5.5	[Volt]	
LED Enable Input Low Level		-	-	0.6	[Volt]	
PWM Logic Input High Level	VPWM_EN	2.2	-	5.5	[Volt]	
PWM Logic Input Low Level		-	-	0.6	[Volt]	
PWM Input Frequency	FPWM	200	1K	10K	Hz	
PWM Duty Ratio	Duty	1 (Note 3)	--	100	%	

Note 1 : Recommend system pull up/down resistor no bigger than 10kohm

Note 2 : measured in panel VIN

Note 3 : If the PWM duty ratio(min) is set between 5% to 1% ·the PWM input frequency should be set below 1KHz .
The brightness-duty characteristic might not be able to keep in it's linearity if the dimming control is operated in 1% to 5% range.

7-4: Signal Interface Characteristic

Table 7-4-1: Pixel Format Image

Following figure shows the relationship of the input signals and LCD pixel format.

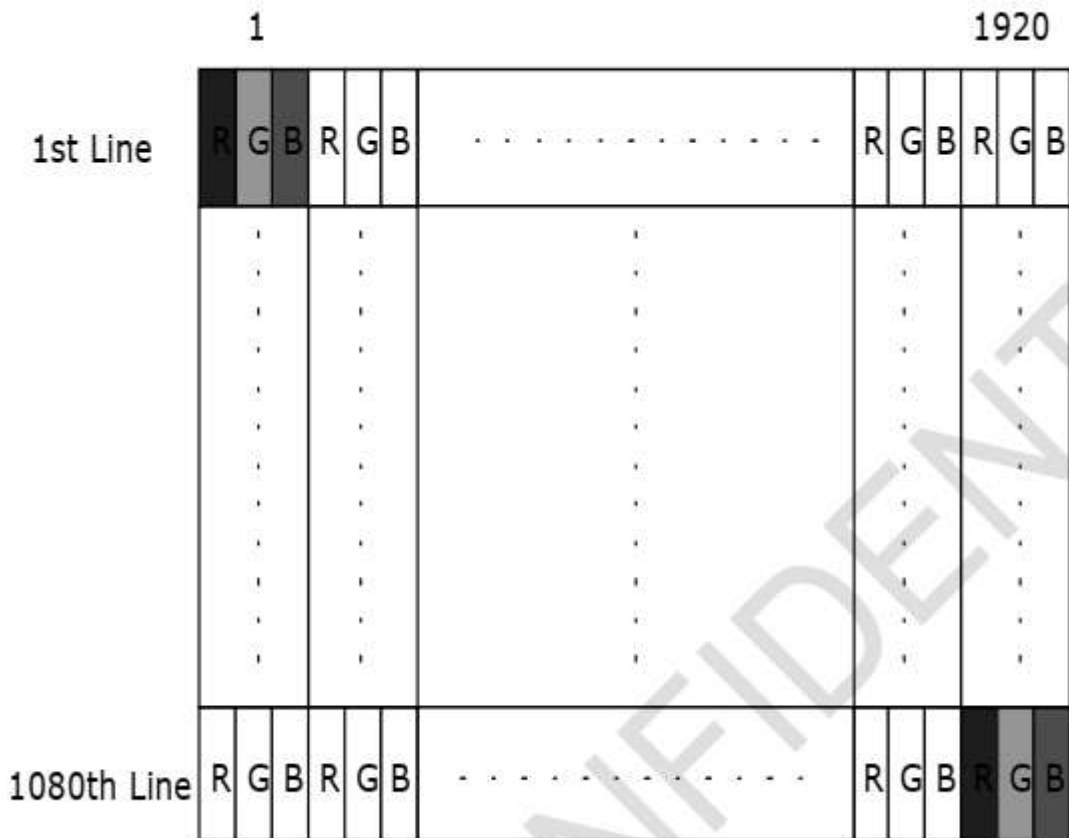

8. Optical Specifications

The optical characteristics are measured under stable conditions at 25°C (Room Temperature) :

Item	Symbol	Conditions	Min.	Typ.	Max.	Unit	Note
White Luminance ILED=23mA (Base Panel Only)		5 points average	325	410		cd/m ²	1, 4, 5.
Viewing Angle	θR θL	Horizontal (Right) CR = 10 (Left)	80 80	85 85	- -	degree	4, 9
	ψH ψL	Vertical (Upper) CR = 10 (Lower)	80 80	85 85	- -		
Luminance Uniformity	δ5P	5 Points	-	-	1.25		1, 3, 4
Luminance Uniformity	δ13P	13 Points	-	-	1.6		2, 3, 4
Contrast Ratio	CR		700	800	-		4, 6
Cross talk	%				4		4, 7
Response Time	TRT	Rising + Falling	-	27	35		
Color / Chromaticity Coordinates	Red	Rx	0.541	0.571	0.601	-	4
		Ry	0.315	0.345	0.375		
	Green	Gx	0.316	0.346	0.376		
		Gy	0.541	0.571	0.601		
	Blue	Bx	0.128	0.158	0.188		
		By	0.09	0.12	0.15		
	White	Wx	0.283	0.313	0.343		
		Wy	0.299	0.329	0.359		
NTSC	%		-	45	-		

Note 1: 5 points position (Ref: Active area)

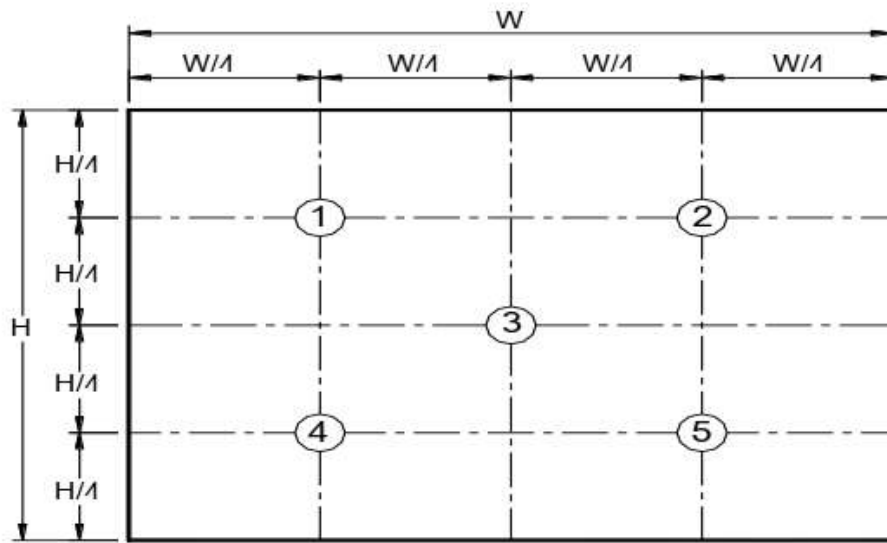

Note 2: 13 points position (Ref: Active area)

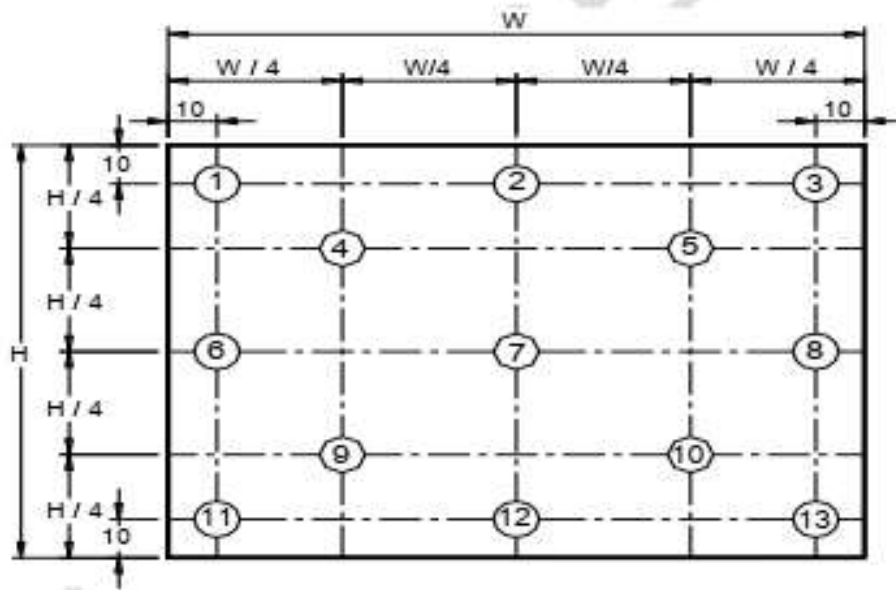

Note 3: The luminance uniformity of 5 or 13 points is defined by dividing the maximum luminance values by the minimum test point luminance

$$\delta_{w5} = \frac{\text{Maximum Brightness of five points}}{\text{Minimum Brightness of five points}}$$

$$\delta_{w13} = \frac{\text{Maximum Brightness of thirteen points}}{\text{Minimum Brightness of thirteen points}}$$

Note 4: Measurement method

The LCD module should be stabilized at given temperature for 30 minutes to avoid abrupt temperature change during measuring. In order to stabilize the luminance, the measurement should be executed after lighting

Backlight for 30 minutes in a stable, windless and dark room, and it should be measured in the center of screen.

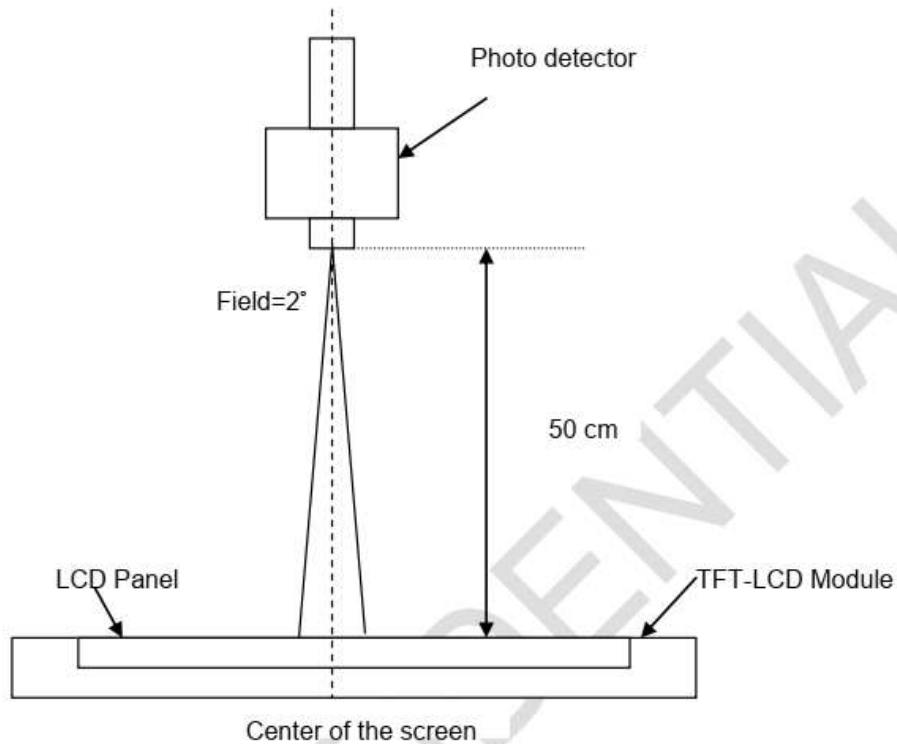

Note 5 : Definition of Average Luminance of White (Y_L):

Measure the luminance of gray level 63 at 5 points · $Y_L = [L (1)+ L (2)+ L (3)+ L (4)+ L (5)] / 5$

$L (x)$ is corresponding to the luminance of the point X at Figure in Note (1).

Note 6 : Definition of contrast ratio:

Contrast ratio is calculated with the following formula.

$$\text{Contrast ratio (CR)} = \frac{\text{Brightness on the "White" state}}{\text{Brightness on the "Black" state}}$$

Note 7 : Definition of Cross Talk (CT)

$$CT = |Y_B - Y_A| / Y_A \times 100 (\%)$$

Where

Y_A = Luminance of measured location without gray level 0 pattern (cd/m^2)

Y_B = Luminance of measured location with gray level 0 pattern (cd/m^2)



Note 8: Definition of response time:

The output signals of BM-7 or equivalent are measured when the input signals are changed from "Black" to "White" (falling time) and from "White" to "Black" (rising time), respectively. The response time interval between the 10% and 90% of amplitudes. Refer to figure as below.

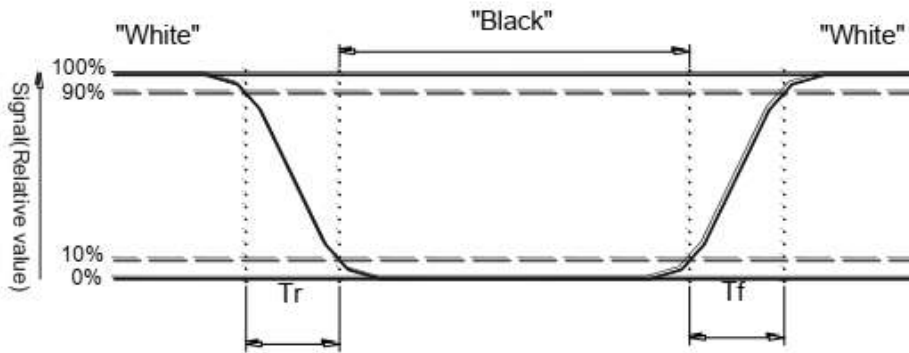

Note 9. Definition of viewing angle

Viewing angle is the measurement of contrast ratio ≥ 10 , at the screen center, over a 180° horizontal and 180° vertical range (off-normal viewing angles). The 180° viewing angle range is broken down as follows; 90° (θ) horizontal left and right and 90° (ϕ) vertical, high (up) and low (down). The measurement direction is typically perpendicular to the display surface with the screen rotated about its center to develop the desired measurement viewing angle.

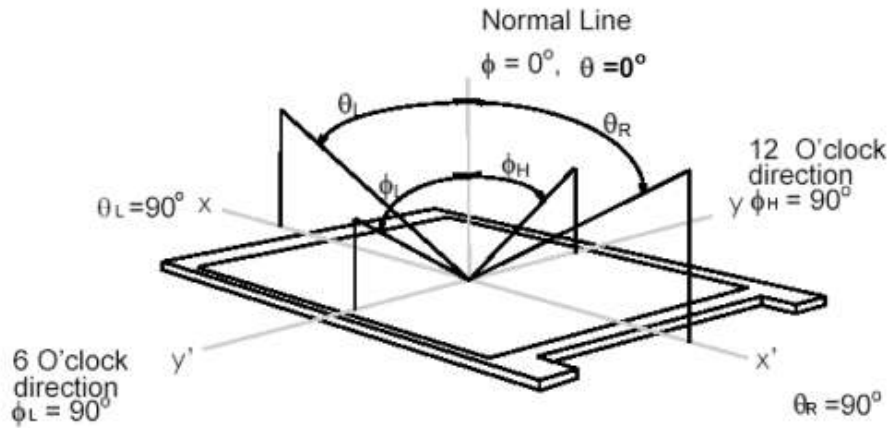

8-1 Functional Block Diagram

Schematic Block Diagram

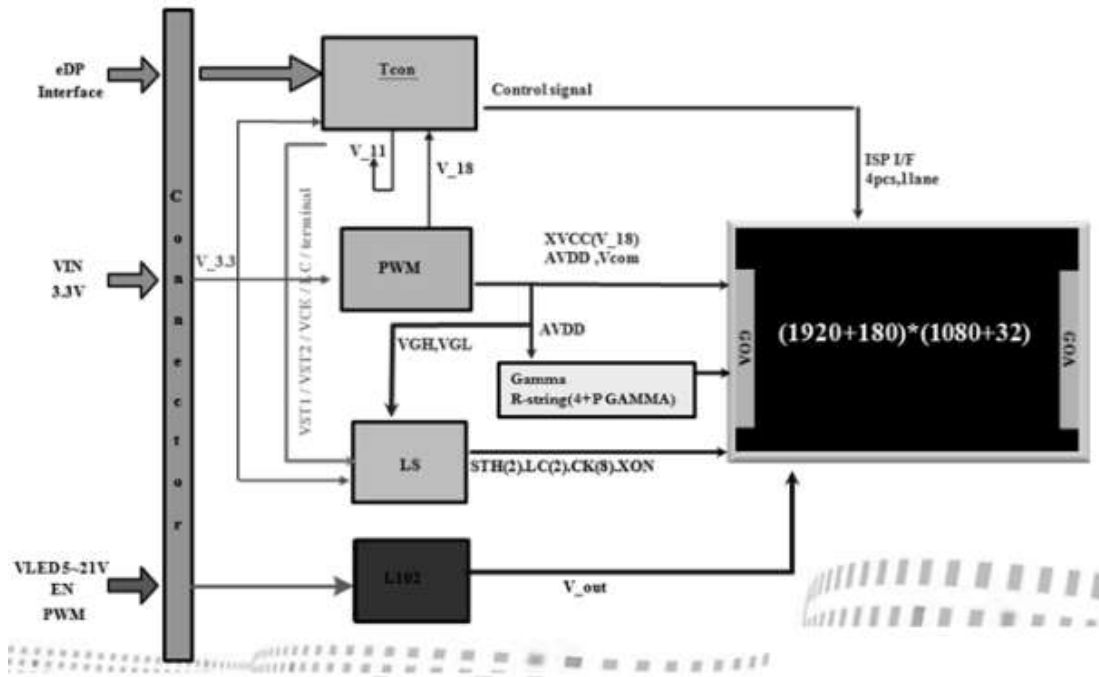

9. Reliability Test Item

9-1. Standard Specifications for Reliability of LCD Module

No	Item	Description
01	High temperature operation	The sample should be allowed to stand at 50°C for 120 hours under driving condition and then returning it to normal temperature condition, and allowing it stand for 2 hours.
02	Low temperature operation	The sample should be allowed to stand at 0°C for 120 hours under driving condition and then returning it to normal temperature condition, and allowing it stand for 2 hours.
03	High temperature storage	The sample should be allowed to stand at 60°C for 120 hours under no-load condition, and then returning it to normal temperature condition and allowing it stand for 2 hours.
04	Low temperature storage	The sample should be allowed to stand at -20°C for 120 hours under no-load condition, then returning it to normal temperature condition, and allowing it stand for 2 hours.
05	Moisture storage	The sample should be allowed to stand at 50°C, 90%RH MAX for 120hours under no-load condition, then taking it out and drying it at normal temperature for 2 hours.
06	Thermal shock storage	The sample should be allowed to stand the following 10 cycles : 0°C for 30 minutes → normal temperature for 5 minutes → +60°C for 30 minutes → normal temperature for 5 minutes, as one cycle.
07	Packing vibration	Frequency range : 10Hz ~ 55Hz Amplitude of vibration : 1.5mm Sweep time: 12 min X, Y, Z 2 hours for each direction.

*Sample size for each test item is 3~5pcs

9 - 2. Testing Conditions and Inspection Criteria

For the final test the testing sample must be stored at room temperature for 24 hours, after the tests listed in Table 10-1, Standard specifications for Reliability have been executed in order to ensure stability.

No	Item	Test Model	In section Criteria
01	Current Consumption	Refer To Specification	The current consumption should conform to the product specification.
02	Contrast	Refer To Specification	After the tests have been executed, the contrast must be larger than half of its initial value prior to the tests.
03	Appearance	Visual inspection	Defect free.

9- 3. MTBF

MTBF	Functions, performance, appearance, etc. shall be free from remarkable deterioration within 50,000 hours under ordinary operating and storage conditions room temperature (25±5°C), normal humidity (50±10% RH), and in area not exposed to direct sun light.
------	---

10. Specification of Quality Assurance:

10-1. Purpose

This standard for Quality Assurance should affirm the quality of LCD module products to supply to purchaser by YEEBO CORPORATION (Supplier).

10-2. Standard for Quality Test

a. Inspection:

Before delivering, the supplier should take the following tests, and affirm the quality of product.

b. Electro-Optical Characteristics:

According to the individual specification to test the product.

c. Test of Appearance Characteristics:

According to the individual specification to test the product.

d. Test of Reliability Characteristics:

According to the definition of reliability on the specification for testing products.

e. Delivery Test:

Before delivering, the supplier should take the delivery test.

(i) Test method: According to ISO2859-1. General Inspection Level II take a single time.

(ii) The defects classify of AQL as following:

Major defect: AQL = 0.65%

Minor defect: AQL = 2.5%

Total defects: AQL = 2.5%

10-3. Non- conforming Analysis & Deal With Manners

a. Non- conforming Analysis:

(i) Purchaser should supply the detail data of non- conforming sample and the non-conforming.

(ii) After accepting the detail data from purchaser, the analysis of non- conforming should be finished in two weeks.

(iii) If supplier can not finish analysis on time, must announce purchaser before 3 days.

b. Disposition of non- conforming:

(i) If find any product defect of supplier during assembly time, supplier must change the good product for every defect after recognition.

(ii) Both supplier and customer should analyze the reason and discuss the disposition of non- conforming when the reason of nonconforming is not sure.

10-4. Agreement items

Both sides should discuss together when the following problems happen.

a. There is any problem of standard of quality assurance, and both sides should think that must be modified.

b. There is any argument item which does not record in the standard of quality assurance.

c. Any other special problem.

10-5. Standard of The Product Appearance Test

a. Manner of appearance test:

(i) The test must be under 20W × 2 or 40W fluorescent light, and the distance of view must be at 30±5cm.

(ii) When test the model of transmissive product must add the reflective plate.

(iii) The test direction is base on around 10° of vertical line.

(iii) Temperature: 25±5°C Humidity: 60±10%RH

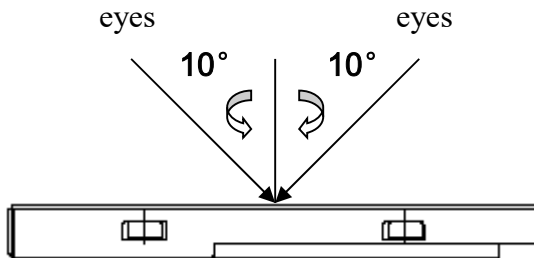

(iv) Definition of area:

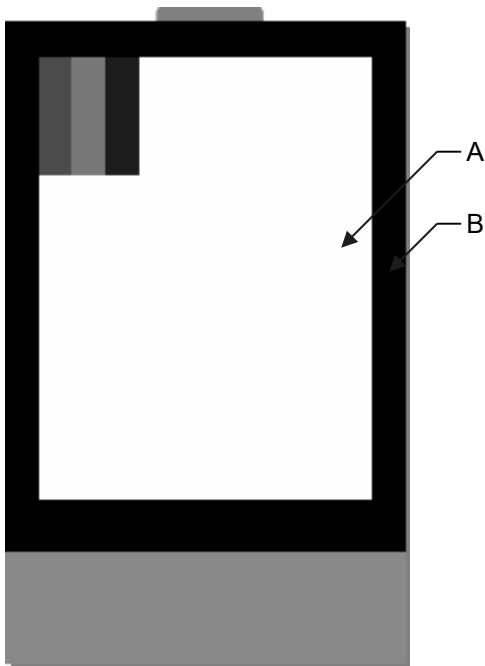

A. Area: Viewing area.

B. Area: Out of viewing area.

(Outside viewing area)

b. Basic principle:

(i) It will accord to the AQL when the standard can not be described.

(ii) The sample of the lowest acceptable quality level must be discussed by both supplier and customer when any dispute happened.

(iii) Must add new item on time when it is necessary.

c. Standard of inspection: (Unit: mm)

10-6. Inspection specification

Defect out of viewing area can be neglected.

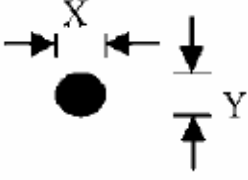
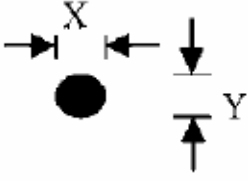
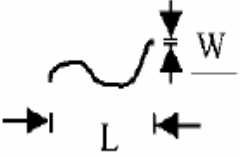
NO	Item	Criterion	AQL										
01	Electrical Testing	1.1 Missing vertical, horizontal segment, segment contrast defect. 1.2 Missing character, dot or icon. 1.3 Display malfunction. 1.4 No function or no display. 1.5 Current consumption exceeds product specifications. 1.6 LCD viewing angle defect. 1.7 Mixed product types. 1.8 Flicker	0.65										
02	Black or White spots or Bright spots or Color spots on LCD (Display only)	2.1 White and black or color spots on display $\leq 0.25\text{mm}$, no more than Five spots. 2.2 Densely spaced: No more than three spots within 3mm. $\Phi = (X+Y) / 2$  <table border="1" data-bbox="829 851 1364 1064"> <thead> <tr> <th>Size(mm)</th> <th>Acceptable Q'ty</th> </tr> </thead> <tbody> <tr> <td>$\Phi \leq 0.20$</td> <td>Accept no dense</td> </tr> <tr> <td>$0.2 < \Phi \leq 0.30$</td> <td>3</td> </tr> <tr> <td>$0.30 < \Phi \leq 0.50$</td> <td>2</td> </tr> <tr> <td>$D > 0.5$</td> <td>0</td> </tr> </tbody> </table>	Size(mm)	Acceptable Q'ty	$\Phi \leq 0.20$	Accept no dense	$0.2 < \Phi \leq 0.30$	3	$0.30 < \Phi \leq 0.50$	2	$D > 0.5$	0	2.5
Size(mm)	Acceptable Q'ty												
$\Phi \leq 0.20$	Accept no dense												
$0.2 < \Phi \leq 0.30$	3												
$0.30 < \Phi \leq 0.50$	2												
$D > 0.5$	0												
03	LCD and Touch Panel black spots, white spots, contamination (non – display)	3.1 Round type: As following drawing $\Phi = (X+Y) / 2$  <table border="1" data-bbox="829 1176 1364 1388"> <thead> <tr> <th>Size(mm)</th> <th>Acceptable Q'ty</th> </tr> </thead> <tbody> <tr> <td>$\Phi \leq 0.15$</td> <td>Accept no dense</td> </tr> <tr> <td>$0.15 < \Phi \leq 0.30$</td> <td>3</td> </tr> <tr> <td>$0.30 < \Phi \leq 0.50$</td> <td>2</td> </tr> <tr> <td>$D > 0.5$</td> <td>0</td> </tr> </tbody> </table> <p style="text-align: center;">* Densely spaced: No more than two spots within 3mm.</p>	Size(mm)	Acceptable Q'ty	$\Phi \leq 0.15$	Accept no dense	$0.15 < \Phi \leq 0.30$	3	$0.30 < \Phi \leq 0.50$	2	$D > 0.5$	0	2.5
		Size(mm)	Acceptable Q'ty										
$\Phi \leq 0.15$	Accept no dense												
$0.15 < \Phi \leq 0.30$	3												
$0.30 < \Phi \leq 0.50$	2												
$D > 0.5$	0												
3.2 Line type: (As following drawing)  <table border="1" data-bbox="694 1579 1364 1769"> <thead> <tr> <th>Length(mm)</th> <th>Width(mm)</th> <th>Acceptable Q'ty</th> </tr> </thead> <tbody> <tr> <td>$L \leq 6$</td> <td>$W \leq 0.05$</td> <td>Accept no dense</td> </tr> <tr> <td>$L \leq 6$</td> <td>$0.05 < W \leq 0.25$</td> <td>2</td> </tr> <tr> <td>$L > 6$</td> <td>$0.25 < W$</td> <td>Rejection</td> </tr> </tbody> </table> <p style="text-align: center;">* Densely spaced: No more than two lines within 3mm.</p>	Length(mm)	Width(mm)	Acceptable Q'ty	$L \leq 6$	$W \leq 0.05$	Accept no dense	$L \leq 6$	$0.05 < W \leq 0.25$	2	$L > 6$	$0.25 < W$	Rejection	2.5
Length(mm)	Width(mm)	Acceptable Q'ty											
$L \leq 6$	$W \leq 0.05$	Accept no dense											
$L \leq 6$	$0.05 < W \leq 0.25$	2											
$L > 6$	$0.25 < W$	Rejection											

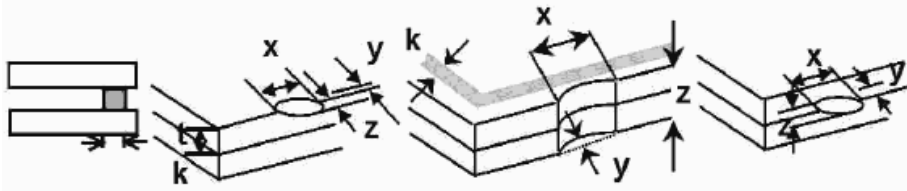
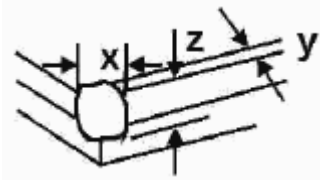
NO	Item	Criterion	AQL																		
04	Polarizer bubbles	<p>If bubbles are visible, judge using black spot specifications, not easy to find, must check in specify direction</p> <table border="1"> <thead> <tr> <th>Size Φ(mm)</th> <th>Acceptable Q'ty</th> </tr> </thead> <tbody> <tr> <td>$\Phi \leq 0.2$</td> <td>Accept no dense</td> </tr> <tr> <td>$0.2 < \Phi \leq 0.30$</td> <td>2</td> </tr> <tr> <td>$0.30 < \Phi \leq 0.50$</td> <td>1</td> </tr> <tr> <td>$0.50 < \Phi \leq 1.0$</td> <td>2</td> </tr> <tr> <td>$1 < \Phi$</td> <td>0</td> </tr> </tbody> </table>	Size Φ (mm)	Acceptable Q'ty	$\Phi \leq 0.2$	Accept no dense	$0.2 < \Phi \leq 0.30$	2	$0.30 < \Phi \leq 0.50$	1	$0.50 < \Phi \leq 1.0$	2	$1 < \Phi$	0	2.5						
Size Φ (mm)	Acceptable Q'ty																				
$\Phi \leq 0.2$	Accept no dense																				
$0.2 < \Phi \leq 0.30$	2																				
$0.30 < \Phi \leq 0.50$	1																				
$0.50 < \Phi \leq 1.0$	2																				
$1 < \Phi$	0																				
05	Scratches	Follow NO.3 -2 Line Type.	2.5																		
06	Chipped glass	<p>Symbols: x: Chip length y: Chip width z: Chip thickness k: Seal width t: Glass thickness a: LCD side length L: Electrode pad length</p> <p>6.1 General glass chip: 6.1.1 Chip on panel surface and crack between panels:</p>  <table border="1"> <thead> <tr> <th>z: Chip thickness</th> <th>y: Chip width</th> <th>x: Chip length</th> </tr> </thead> <tbody> <tr> <td>$Z \leq 1/2t$</td> <td>Not over viewing area</td> <td>$x \leq 1/8a$</td> </tr> <tr> <td>$1/2t < z \leq 2t$</td> <td>Not exceed 1/3k</td> <td>$x \leq 1/8a$</td> </tr> </tbody> </table> <p>⊙ Unit: mm ⊙ If there are 2 or more chips, x is the total length of each chip</p> <p>6.1.2 Corner crack:</p>  <table border="1"> <thead> <tr> <th>z: Chip thickness</th> <th>y: Chip width</th> <th>x: Chip length</th> </tr> </thead> <tbody> <tr> <td>$Z \leq 1/2t$</td> <td>Not over viewing area</td> <td>$x \leq 1/8a$</td> </tr> <tr> <td>$1/2t < z \leq 2t$</td> <td>Not exceed 1/3k</td> <td>$x \leq 1/8a$</td> </tr> </tbody> </table> <p>⊙ Unit: mm ⊙ If there are 2 or more chips, x is the total length of each chip</p>	z: Chip thickness	y: Chip width	x: Chip length	$Z \leq 1/2t$	Not over viewing area	$x \leq 1/8a$	$1/2t < z \leq 2t$	Not exceed 1/3k	$x \leq 1/8a$	z: Chip thickness	y: Chip width	x: Chip length	$Z \leq 1/2t$	Not over viewing area	$x \leq 1/8a$	$1/2t < z \leq 2t$	Not exceed 1/3k	$x \leq 1/8a$	2.5
z: Chip thickness	y: Chip width	x: Chip length																			
$Z \leq 1/2t$	Not over viewing area	$x \leq 1/8a$																			
$1/2t < z \leq 2t$	Not exceed 1/3k	$x \leq 1/8a$																			
z: Chip thickness	y: Chip width	x: Chip length																			
$Z \leq 1/2t$	Not over viewing area	$x \leq 1/8a$																			
$1/2t < z \leq 2t$	Not exceed 1/3k	$x \leq 1/8a$																			

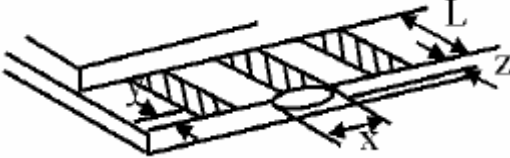
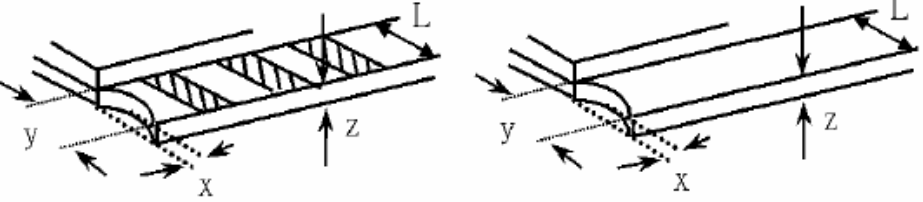
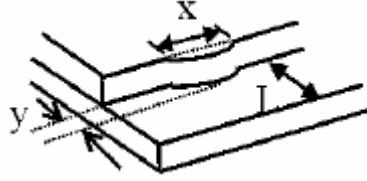
NO	Item	Criterion	AQL																
07	Glass crack	<p>Symbols: x: Chip length y: Chip width z: Chip thickness k: Seal width t: Glass thickness a: LCD side length L: Electrode pad length</p> <p>7.2 Protrusion over terminal: 7.2.1 Chip on electrode pad:</p>  <table border="1" data-bbox="550 683 1228 828"> <tr> <td>y: Chip width</td> <td>x: Chip length</td> <td>z: Chip thickness</td> </tr> <tr> <td>$y \leq 0.5\text{mm}$</td> <td>$x \leq 1/8a$</td> <td>$0 < z \leq t$</td> </tr> </table> <p>7.2.2 Non-conductive portion:</p>  <table border="1" data-bbox="550 1198 1228 1344"> <tr> <td>y: Chip width</td> <td>x: Chip length</td> <td>z: Chip thickness</td> </tr> <tr> <td>$y \leq L$</td> <td>$x \leq 1/8a$</td> <td>$0 < z \leq t$</td> </tr> </table> <p>⊙ If there chipped area touches the ITO terminal, over 2/3 of the ITO must remain and be inspected according to electrode terminal specifications. ⊙ If the product will be heat sealed by the customer, the alignment mark must not be damaged.</p> <p>7.2.3 Substrate protuberance and internal crack</p>  <table border="1" data-bbox="869 1668 1300 1814"> <tr> <td>y: width</td> <td>x: length</td> </tr> <tr> <td>$y \leq 1/3L$</td> <td>$X \leq a$</td> </tr> </table>	y: Chip width	x: Chip length	z: Chip thickness	$y \leq 0.5\text{mm}$	$x \leq 1/8a$	$0 < z \leq t$	y: Chip width	x: Chip length	z: Chip thickness	$y \leq L$	$x \leq 1/8a$	$0 < z \leq t$	y: width	x: length	$y \leq 1/3L$	$X \leq a$	2.5
y: Chip width	x: Chip length	z: Chip thickness																	
$y \leq 0.5\text{mm}$	$x \leq 1/8a$	$0 < z \leq t$																	
y: Chip width	x: Chip length	z: Chip thickness																	
$y \leq L$	$x \leq 1/8a$	$0 < z \leq t$																	
y: width	x: length																		
$y \leq 1/3L$	$X \leq a$																		

NO	Item	Criterion	AQL
08	Cracked glass	The LCD with extensive crack is not acceptable.	2.5
09	Backlight elements	9.1 Illumination source flickers when lit. 9.2 Spots or scratches that appear when lit must be judged. Using LCD spot, lines and contamination standards. 9.3 Backlight doesn't light or color is wrong.	2.5 2.5 0.65
10	Bezel	Bezel must comply with product specifications.	2.5
11	PCB、COB	11.1 COB seal may not have pinholes larger than 0.2mm or contamination. 11.2 COB seal surface may not have pinholes through to the IC. 11.3 The height of the COB should not exceed the height indicated in the assembly diagram. 11.4 There may not be more than 2mm of sealant outside the seal area on PCB. And there should be no more than three places. 11.5 Parts on PCB must be the same as on the production characteristic chart, There should be no wrong parts, missing parts or excess parts. 11.6 The jumper on the PCB should conform to the product characteristic chart.	2.5 2.5 2.5 2.5 0.65 0.65
12	FPC	12.1 FPC terminal damage \cong 1/2 FPC terminal width and can not affect the function, we judge accept. 12.2 FPC alignment hole damage \cong 1/2 alignment area and can not affect the function, we judge accept.	2.5 2.5
13	Soldering	13.1 No cold solder joints, missing solder connections, oxidation or icicle. 13.2 No short circuits in components on PCB or FPC.	2.5 0.65

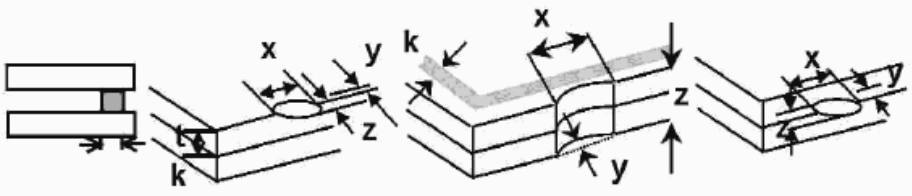
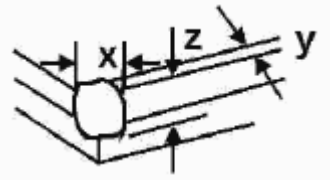
NO	Item	Criterion	AQL												
14	Touch Panel Chipped glass	<p>Symbols: x: Chip length y: Chip width z: Chip thickness k: Seal width t: Touch Panel Total thickness a: LCD side length L: Electrode pad length</p> <p>14.1 General glass chip: 14.1.1 Chip on panel surface and crack between panels:</p>  <table border="1" data-bbox="416 797 1235 1014"> <tr> <td>z: Chip thickness</td> <td>y: Chip width</td> <td>x: Chip length</td> </tr> <tr> <td>$Z \leq t$</td> <td>$\leq 1/2 k$ and not over viewing area</td> <td>$x \leq 1/8a$</td> </tr> </table> <p>⊙ Unit: mm ⊙ If there are 2 or more chips, x is the total length of each chip</p> <p>14.1.2 Corner crack:</p>  <table border="1" data-bbox="416 1395 1235 1612"> <tr> <td>z: Chip thickness</td> <td>y: Chip width</td> <td>x: Chip length</td> </tr> <tr> <td>$z \leq t$</td> <td>$\leq 1/2 k$ and not over viewing area</td> <td>$x \leq 1/8a$</td> </tr> </table> <p>⊙ Unit: mm ⊙ If there are 2 or more chips, x is the total length of each chip</p>	z: Chip thickness	y: Chip width	x: Chip length	$Z \leq t$	$\leq 1/2 k$ and not over viewing area	$x \leq 1/8a$	z: Chip thickness	y: Chip width	x: Chip length	$z \leq t$	$\leq 1/2 k$ and not over viewing area	$x \leq 1/8a$	2.5
z: Chip thickness	y: Chip width	x: Chip length													
$Z \leq t$	$\leq 1/2 k$ and not over viewing area	$x \leq 1/8a$													
z: Chip thickness	y: Chip width	x: Chip length													
$z \leq t$	$\leq 1/2 k$ and not over viewing area	$x \leq 1/8a$													

NO	Item	Criterion	AQL						
15	Touch Panel(Fish eye)	<table border="1"> <tr> <td>SIZE(mm)</td> <td>Acceptable Q'ty</td> </tr> <tr> <td>$L \leq 0.7$</td> <td>Accept no dense</td> </tr> <tr> <td>$0.7 < L$</td> <td>0</td> </tr> </table>	SIZE(mm)	Acceptable Q'ty	$L \leq 0.7$	Accept no dense	$0.7 < L$	0	2.5
		SIZE(mm)	Acceptable Q'ty						
$L \leq 0.7$	Accept no dense								
$0.7 < L$	0								
<p style="text-align: center;">L</p> 									
16	Touch Panel Newton ring	Newton ring dimension $\leq 1/2$ touch panel area and not affect font and line distortion ($\leq 2.5\%$), it is acceptable.	2.5						
17	Touch Panel Linearity	Less than 2.5% is acceptable.	2.5						
18	LCD Ripple	Touch the touch panel, can not see the LCD ripple. Pen: R 1.0mm silicon rubber. Operation Force: 80g	2.5						
19	General appearance	19.1 Pin type must match type in specification sheet.	0.65						
		19.2 LCD pin loose or missing pins.	0.65						
		19.3 Product packaging must the same as specified on packaging specification sheet.	0.65						
		19.4 Product dimension and structure must conform to product specification sheet.	0.65						

11. Handling Precaution:

11-1 Handling of LCM

- Don't give external shock.
- Don't apply excessive force on the surface.
- Liquid in LCD is hazardous substance. Must not lick and swallow. when the liquid is attach to your hand, skin, cloth etc. Wash it out thoroughly and immediately.
- Don't operate it above the absolute maximum rating.
- Don't disassemble the LCM.
- The operators should be grounded whenever he/she comes into contact with the module. Never touch any of the conductive parts such as the LSI pads, the copper leads on the PCB and the interface terminals with any parts of the human body.
- The modules should be kept in antistatic bags or other containers resistant to static for storage.
- The module is coated with a film to protect the display surface. Be care when peeling off this protective film since static electricity may be generated.

11-2 Storage

- Store in an ambient temperature of $25\pm 10^{\circ}\text{C}$, and in a relative humidity of $50\pm 10\%\text{RH}$, and must be used within six months after delivery from our factory.
Don't expose to sunlight or fluorescent light.
- Storage in a clean environment, free from dust, active gas, and solvent.
- Store in anti-static electricity container.
- Store without any physical load
- Appearance, 3 months; Function, 1 year; within the validity, failed CTP can be replaced 1 to 1

11-3 Soldering

- Use only soldering irons with proper grounding and no leakage.
- Iron: No higher than $280\pm 10^{\circ}\text{C}$ and less than 3 sec during Hand soldering.
- Rewiring: no more than 2 times.

12. Guarantee:

Our products meet requirements of the environment.
YEEBO ROHS requirement is based on European Union Directive 2011/65/EU (ROHS) Requirements and Update.